

# Planetary Gearhead GP 22 B $\varnothing 22$ mm, 0.1 - 0.3 Nm

Sleeve Bearing

maxon gear

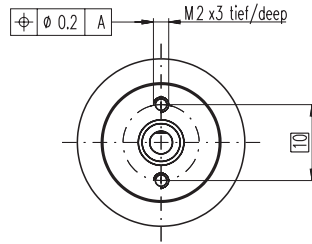
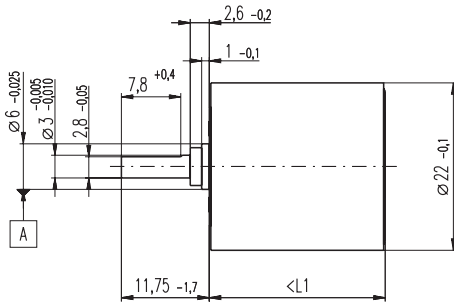

M 1:1

## Technical Data

Planetary Gearhead	straight teeth
Housing	steel
Output shaft	stainless steel, hardened
Bearing at output	sleeve bearing
Radial play, 6 mm from flange	max. 0.06 mm
Axial play	0.02 - 0.10 mm
Max. permissible axial load	8 N
Max. permissible force for press fits	100 N
Sense of rotation, drive to output	=
Recommended input speed	< 8000 rpm
Recommended temperature range	-15 ... +100°C
Extended area as option	-35 ... +100°C
Number of stages	1 2 3 4 5
Max. radial load, 6 mm from flange	8 N 12 N 16 N 20 N 20 N

- Stock program
- Standard program
- Special program (on request)

## Order Number

110355	110356	110357	118653	110358	134772	110359	134775
--------	--------	--------	--------	--------	--------	--------	--------

## Gearhead Data

1 Reduction	4.4 : 1	19 : 1	84 : 1	157 : 1	370 : 1	690 : 1	1621 : 1	3027 : 1
2 Reduction absolute	57/13	3249/169	185193/2197	19683/125	10556001/28561	1121931/1625	601692057/371293	63950067/21125
3 Max. motor shaft diameter	mm	2	2	15	2	2	2	2
<b>Order Number</b>		118651	134767	134768	134770	118654	134773	134776
1 Reduction	5.4 : 1	24 : 1	104 : 1		455 : 1	850 : 1	1996 : 1	3728 : 1
2 Reduction absolute	27/5	1539/65	87723/845		5000211/10985	531441/625	285012027/142805	30292137/8125
3 Max. motor shaft diameter	mm	1.5	2	2	2	1.5	2	2
<b>Order Number</b>		118652	134769		134771		134774	118655
1 Reduction		29 : 1	128 : 1		561 : 1		2458 : 1	4592 : 1
2 Reduction absolute		729/25	41553/325		2368521/4225		135005697/54925	14348907/3125
3 Max. motor shaft diameter	mm	1.5	2		2		2	1.5
4 Number of stages		1	2	3	3	4	4	5
5 Max. continuous torque	Nm	0.10	0.15	0.20	0.20	0.25	0.25	0.30
6 Intermittently permissible torque at gear output	Nm	0.150	0.225	0.300	0.300	0.375	0.375	0.450
7 Max. efficiency	%	90	81	73	73	65	65	59
8 Weight	g	39	48	57	57	65	65	73
9 Average backlash no load	°	1.4	1.6	2.0	2.0	2.4	2.4	3.0
10 Mass inertia	gcm <sup>2</sup>	0.07	0.05	0.05	0.05	0.05	0.05	0.05
11 Gearhead length L1	mm	15.9	19.5	23.1	23.1	26.7	26.7	30.3

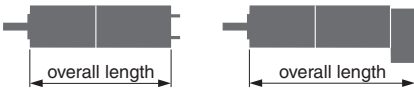

## Combination

+ Motor	Page	+ Tacho / Brake	Page	Overall length [mm] = Motor length + gearhead length + (tacho / brake) + assembly parts							
A-max 19	107/108			44.9	48.5	52.1	52.1	55.7	55.7	59.3	59.3
A-max 19, 1.5 W	108	MR	255/256	50.0	53.6	57.2	57.2	60.8	60.8	64.4	64.4
A-max 19, 1.5 W	108	Enc 22	261	59.3	62.9	66.5	66.5	70.1	70.1	73.7	73.7
A-max 19, 1.5 W	108	MEnc 13	270	52.4	56.0	59.6	59.6	63.2	63.2	66.8	66.8
A-max 19, 2.5 W	109/110			47.5	51.1	54.7	54.7	58.3	58.3	61.9	61.9
A-max 19, 2.5 W	110	MR	255/256	51.8	55.4	59.0	59.0	62.6	62.6	66.2	66.2
A-max 19, 2.5 W	110	Enc 22	261	61.9	65.5	69.1	69.1	72.7	72.7	76.3	76.3
A-max 19, 2.5 W	110	MEnc 13	270	55.0	58.6	62.2	62.2	65.8	65.8	69.4	69.4
A-max 22	111-114			47.9	51.5	55.1	55.1	58.7	58.7	62.3	62.3
A-max 22	112/114	MR	255/256	52.9	56.5	60.1	60.1	63.7	63.7	67.3	67.3
A-max 22	112/114	Enc 22	261	62.3	65.9	69.5	69.5	73.1	73.1	76.7	76.7
A-max 22	112/114	MEnc 13	270	55.0	58.6	62.2	62.2	65.8	65.8	69.4	69.4

## Option Ball Bearing

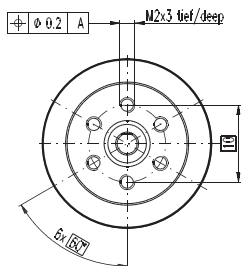

## Order Number

4.4 : 1	144137	455 : 1	144147
5.4 : 1	144138	561 : 1	144148
19 : 1	144139	690 : 1	144149
24 : 1	144140	850 : 1	144150
29 : 1	144141	1621 : 1	144151
84 : 1	144142	1996 : 1	144152
104 : 1	144143	2458 : 1	144153
128 : 1	144144	3027 : 1	144154
157 : 1	144145	3728 : 1	144155
370 : 1	144146	4592 : 1	144156

## Technical Data

Planetary Gearhead	straight teeth
Housing	steel
Output shaft	stainless steel, hardened
Bearing at output	preloaded ball bearings
Radial play, 6 mm from flange	< 0.08 mm
Axial play at axial load	< 4 N 0 mm > 4 N max. 0.05 mm
Max. permissible axial load	8 N
Max. permissible force for press fits	25 N
Sense of rotation, drive to output	=
Recommended input speed	< 8000 rpm
Recommended temperature range	-15 ... +100°C
Extended area as option	-35 ... +100°C
Number of stages	1 2 3 4 5
Max. radial load, 6 mm from flange	10 N 15 N 20 N 20 N 20 N
Gearhead values according to sleeve bearing version	