

Spur Gearhead GS 16 K $\varnothing 16$ mm, 0.01 - 0.03 Nm

Plastic Version

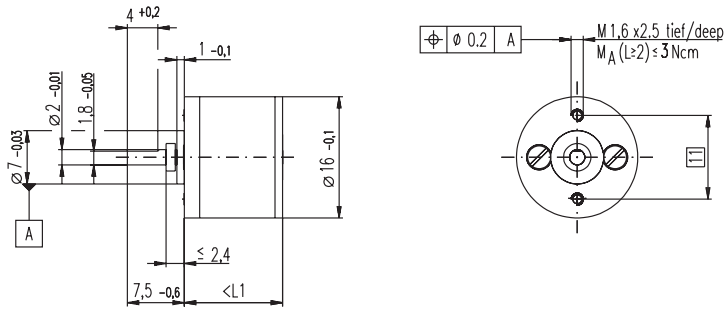

M 1:1

Technical Data

Spur Gearhead	straight teeth
Output shaft	stainless steel, hardened
Bearing at output	sleeve bearing
Radial play, 6.5 mm from flange	max. 0.15 mm
Axial play	0.02 - 0.12 mm
Max. radial load, 6.5 mm from flange	1 N
Max. permissible axial load	2 N
Max. permissible force for press fits	15 N
Recommended input speed	< 8000 rpm
Recommended temperature range	-15 ... +80°C
Extended area as option	-35 ... +80°C

- Stock program
- Standard program
- Special program (on request)

Order Number

Gearhead Data	Order Number						
	201463	201465	201467	201469	201471	201473	
Order Number	207405	207406	207407	207408	207409	207410	
1 Reduction	9.1 : 1	31 : 1	108 : 1	371 : 1	1278 : 1	4402 : 1	
2 Reduction absolute	899/99	27869/891	863939/8019	26782109/72171	830245379/649539	25737606749/5845851	
3 Max. motor shaft diameter	mm	1.5	1.5	1.5	1.5	1.5	
Order Number	201464	201466	201468	201470	201472	201474	
1 Reduction	12 : 1	41 : 1	141 : 1	485 : 1	1670 : 1	5752 : 1	
2 Reduction absolute	961/81	29791/729	923521/6561	28629151/59049	887503681/531441	27512614111/4782969	
3 Max. motor shaft diameter	mm	1	1	1	1	1	
4 Number of stages		2	3	4	5	6	7
5 Max. continuous torque	Nm	0.010	0.020	0.030	0.030	0.030	0.030
6 Intermittently permissible torque at gear output	Nm	0.10	0.10	0.10	0.10	0.10	0.10
7 Sense of rotation, drive to output		=	≠	=	≠	=	≠
8 Max. efficiency	%	81	73	66	59	53	48
9 Weight	g	9.0	9.8	10.2	10.7	11.3	11.7
10 Average backlash no load	°	1.0	1.0	1.2	1.2	1.5	1.5
11 Mass inertia	gcm ²	0.0032	0.0031	0.0031	0.0031	0.0031	0.0031
12 Gearhead length L1	mm	11.8	12.8	14.8	16.8	18.8	20.8

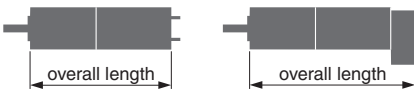

Combination

+ Motor	Page	+ Tacho / Brake	Page	Overall length [mm] = Motor length + gearhead length + (tacho / brake) + assembly parts					
A 2516, 0.8 W	88			29.3	30.3	32.3	34.3	36.3	38.3
A 2516, 0.8 W	88	MEnc 13	270	36.6	37.6	39.6	41.6	43.6	45.6
A-max 16	103-106			37.3	38.3	40.3	42.3	44.3	46.3
A-max 16	104/106	MR	255/256	42.3	43.3	45.3	47.3	49.3	51.3
A-max 16	104/106	MEnc 13	270	45.4	46.4	48.4	50.4	52.4	54.4