

F 2140 Ø40 mm, Precious Metal Brushes CLL, 4 Watt, CE approved

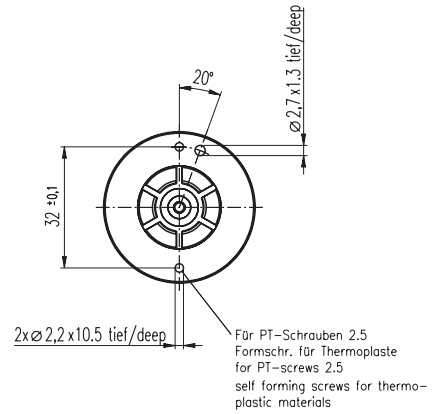
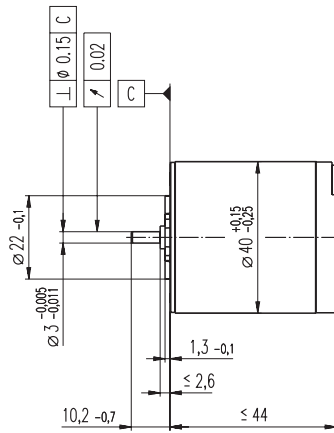
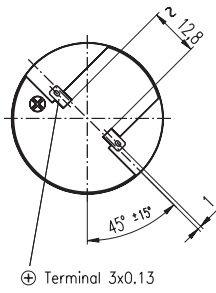

M 1:2

- Stock program
- Standard program
- Special program (on request)

Order Number

2140. ... -22.112-050 (Insert winding number)

Motor Data	Winding number	Order Number							
		931	932	933	934	935	936	937	939
Values at nominal voltage									
1 Nominal voltage	V	6.0	9.0	9.0	12.0	15.0	18.0	24.0	36.0
2 No load speed	rpm	3940	4630	3740	4090	4080	3850	4110	4130
3 No load current	mA	23.1	20.1	14.2	12.3	9.77	7.43	6.19	4.17
4 Nominal speed	rpm	2270	2990	2080	2430	2410	2160	2420	2400
5 Nominal torque (max. continuous torque)	mNm	13.8	13.9	13.9	13.9	13.8	13.6	13.6	13.3
6 Nominal current (max. continuous current)	A	0.974	0.773	0.624	0.508	0.404	0.314	0.251	0.164
7 Stall torque	mNm	32.6	39.5	31.6	34.2	33.9	31.2	33.1	31.8
8 Starting current	A	2.26	2.15	1.39	1.23	0.974	0.706	0.601	0.387
9 Max. efficiency	%	81	82	81	82	81	81	81	81
Characteristics									
10 Terminal resistance	Ω	2.65	4.19	6.47	9.73	15.4	25.5	40.0	93.0
11 Terminal inductance	mH	0.341	0.558	0.853	1.27	1.99	3.21	5.02	11.2
12 Torque constant	mNm / A	14.4	18.4	22.7	27.8	34.8	44.1	55.2	82.3
13 Speed constant	rpm / V	664	519	420	344	275	216	173	116
14 Speed / torque gradient	rpm / mNm	122	118	120	121	122	125	125	131
15 Mechanical time constant	ms	32.2	31.9	31.9	31.9	32.0	32.1	32.1	32.5
16 Rotor inertia	gcm ²	25.1	25.7	25.5	25.3	25.1	24.6	24.5	23.6

Specifications

Thermal data	
17 Thermal resistance housing-ambient	10.4 K / W
18 Thermal resistance winding-housing	8.8 K / W
19 Thermal time constant winding	45.5 s
20 Thermal time constant motor	988 s
21 Ambient temperature	-20 ... +65°C
22 Max. permissible winding temperature	+85°C
Mechanical data (sleeve bearings)	
23 Max. permissible speed	6400 rpm
24 Axial play	0.2 - 0.3 mm
25 Radial play	0.025 mm
26 Max. axial load (dynamic)	0.5 N
27 Max. force for press fits (static)	50 N
28 Max. radial loading, 5 mm from flange	2.5 N

Other specifications

29 Number of pole pairs	1
30 Number of commutator segments	7
31 Weight of motor	190 g
CLL = Capacitor Long Life	

Values listed in the table are nominal.
Explanation of the figures on page 49.

Option

Ball bearings in place of sleeve bearings

Operating Range

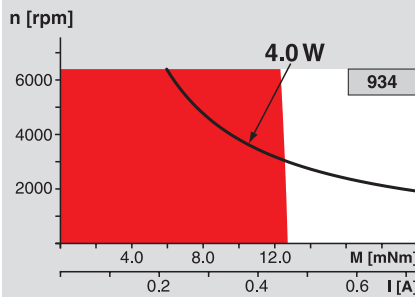

Comments

Continuous operation
In observation of above listed thermal resistance (lines 17 and 18) the maximum permissible winding temperature will be reached during continuous operation at 25°C ambient.
= Thermal limit.

Short term operation
The motor may be briefly overloaded (recurring).

— Assigned power rating

maxon Modular System

Overview on page 16 - 21

Spur Gearhead
Ø38 mm
0.1 - 0.6 Nm
Page 243

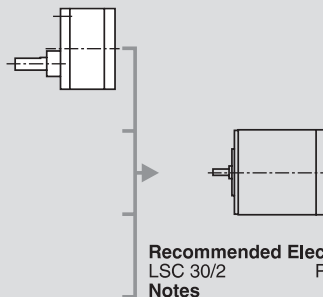

Recommended Electronics:
LSC 30/2 Page 276
Notes 18