

# RE 16 $\varnothing 16$ mm, Precious Metal Brushes CLL, 3.2 Watt, $\text{C}\epsilon$ approved

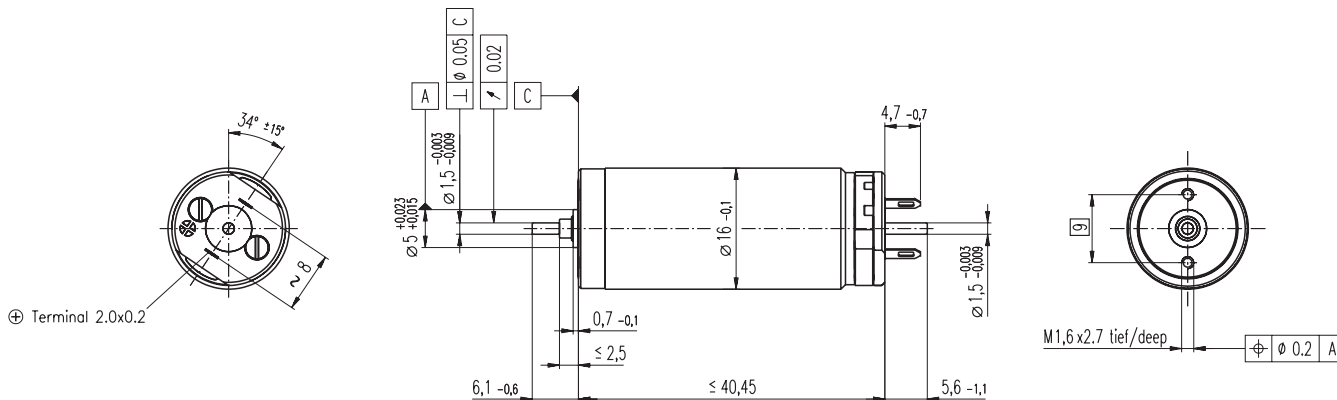

## M 1:1

- Stock program
- Standard program
- Special program (on request)

### Order Number

Motor Data	118693	118694	118695	118696	118697	118698	118699	118700	118701	118702	118703	118704	118705	118706	118707
------------	--------	--------	--------	--------	--------	--------	--------	--------	--------	--------	--------	--------	--------	--------	--------

Values at nominal voltage		1.8	2.4	3.0	3.2	4.5	4.8	7.2	9.0	12.0	12.0	15.0	18.0	24.0	30.0	48.0	
1	Nominal voltage	V	1.8	2.4	3.0	3.2	4.5	4.8	7.2	9.0	12.0	12.0	15.0	18.0	24.0	30.0	48.0
2	No load speed	rpm	4990	6360	6890	6270	6740	5700	6890	6740	7130	5990	6010	5900	7250	6460	5500
3	No load current	mA	23.5	25.4	22.9	18.6	14.8	10.8	9.56	7.39	6.05	4.63	3.72	3.02	3.11	2.08	1.02
4	Nominal speed	rpm	4220	5420	5740	4860	4990	3610	4790	4620	5020	3830	3840	3720	5070	4220	3180
5	Nominal torque (max. continuous torque)	mNm	2.39	2.50	2.89	3.41	4.48	5.55	5.50	5.46	5.47	5.37	5.35	5.33	5.28	5.18	5.01
6	Nominal current (max. continuous current)	A	0.720	0.720	0.720	0.720	0.720	0.703	0.562	0.436	0.347	0.286	0.229	0.187	0.171	0.119	0.0614
7	Stall torque	mNm	15.5	16.9	17.3	15.2	17.4	15.2	18.1	17.4	18.6	14.9	14.9	14.5	17.6	15.0	11.9
8	Starting current	A	4.53	4.71	4.19	3.13	2.74	1.90	1.82	1.37	1.16	0.784	0.628	0.500	0.561	0.341	0.144
9	Max. efficiency	%	86	86	86	85	86	86	86	86	85	85	85	86	85	84	
Characteristics																	
10	Terminal resistance	$\Omega$	0.397	0.510	0.715	1.02	1.64	2.53	3.95	6.56	10.3	15.3	23.9	36.0	42.8	88.0	333
11	Terminal inductance	mH	0.0207	0.0227	0.0302	0.0415	0.0711	0.113	0.174	0.284	0.452	0.639	0.993	1.48	1.75	3.44	12.1
12	Torque constant	mNm / A	3.43	3.58	4.13	4.84	6.34	7.99	9.92	12.7	16.0	19.0	23.7	28.9	31.4	44.1	82.7
13	Speed constant	rpm / V	2790	2660	2310	1970	1510	1190	962	753	597	502	403	330	304	217	115
14	Speed / torque gradient	rpm / mNm	323	379	400	415	391	378	383	389	386	404	406	410	414	432	465
15	Mechanical time constant	ms	5.81	5.67	5.53	5.43	5.33	5.28	5.26	5.26	5.24	5.26	5.27	5.28	5.28	5.33	5.39
16	Rotor inertia	gcm <sup>2</sup>	1.72	1.43	1.32	1.25	1.30	1.33	1.31	1.29	1.29	1.24	1.24	1.23	1.22	1.18	1.11

Specifications		
Thermal data		
17	Thermal resistance housing-ambient	30 K / W
18	Thermal resistance winding-housing	8.5 K / W
19	Thermal time constant winding	10.5 s
20	Thermal time constant motor	570 s
21	Ambient temperature	-20 ... +65°C
22	Max. permissible winding temperature	+85°C
Mechanical data (sleeve bearings)		
23	Max. permissible speed	11000 rpm
24	Axial play	0.05 - 0.15 mm
25	Radial play	0.014 mm
26	Max. axial load (dynamic)	0.8 N
27	Max. force for press fits (static) (static, shaft supported)	15 N / 70 N
28	Max. radial loading, 5 mm from flange	1.5 N

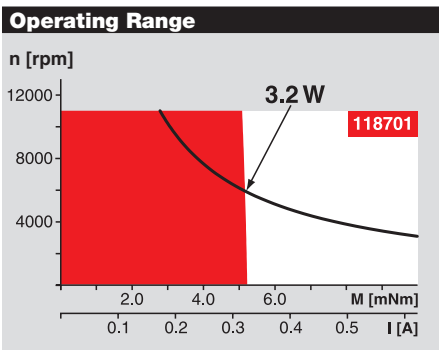

**Comments**

**Continuous operation**  
In observation of above listed thermal resistance (lines 17 and 18) the maximum permissible winding temperature will be reached during continuous operation at 25°C ambient.  
= Thermal limit.

**Short term operation**  
The motor may be briefly overloaded (recurring).

— **Assigned power rating**

Other specifications	
29	Number of pole pairs
30	Number of commutator segments
31	Weight of motor
	CLL = Capacitor Long Life
	Values listed in the table are nominal. Explanation of the figures on page 49.

### maxon Modular System Overview on page 16 - 21

