

RE 10 \varnothing 10 mm, Precious Metal Brushes, 1.5 Watt, CE approved

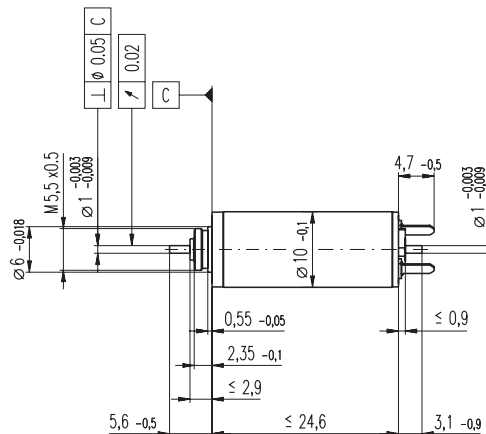
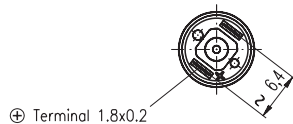

M 1:1

- Stock program
- Standard program
- Special program (on request)

Order Number										
256096	256097	256099	256100	256101	256102	256103	256104	256105		

Motor Data		256096	256097	256099	256100	256101	256102	256103	256104	256105	
Values at nominal voltage											
1	Nominal voltage	V	2.4	2.4	4.5	4.5	6.0	7.2	9.0	10.0	12.0
2	No load speed	rpm	10400	8550	12800	10600	12400	11900	12200	12300	12500
3	No load current	mA	21.7	17.0	15.1	11.8	10.8	8.55	7.06	6.45	5.50
4	Nominal speed	rpm	4100	2180	6500	4190	6140	5890	6070	6240	6500
5	Nominal torque (max. continuous torque)	mNm	1.49	1.48	1.48	1.47	1.50	1.56	1.53	1.53	1.54
6	Nominal current (max. continuous current)	A	0.707	0.579	0.460	0.378	0.338	0.281	0.226	0.207	0.176
7	Stall torque	mNm	2.49	2.02	3.04	2.47	3.01	3.13	3.08	3.14	3.24
8	Starting current	A	1.15	0.771	0.919	0.619	0.660	0.549	0.444	0.412	0.360
9	Max. efficiency	%	75	73	76	75	76	77	77	77	77
Characteristics											
10	Terminal resistance	Ω	2.08	3.11	4.90	7.27	9.09	13.1	20.3	24.3	33.3
11	Terminal inductance	mH	0.0173	0.0253	0.0402	0.0586	0.0766	0.120	0.178	0.215	0.299
12	Torque constant	mNm / A	2.16	2.62	3.30	3.99	4.56	5.70	6.95	7.63	9.00
13	Speed constant	rpm / V	4410	3640	2890	2400	2100	1680	1370	1250	1060
14	Speed / torque gradient	rpm / mNm	4240	4330	4280	4370	4180	3860	4010	3980	3930
15	Mechanical time constant	ms	4.60	4.58	4.57	4.57	4.55	4.54	4.56	4.54	4.53
16	Rotor inertia	gcm ²	0.103	0.101	0.102	0.0998	0.104	0.112	0.109	0.109	0.110

Specifications	Operating Range	Comments
<p>Thermal data</p> <p>17 Thermal resistance housing-ambient 37.5 K / W</p> <p>18 Thermal resistance winding-housing 9.0 K / W</p> <p>19 Thermal time constant winding 2.21 s</p> <p>20 Thermal time constant motor 188 s</p> <p>21 Ambient temperature -20 ... +65°C</p> <p>22 Max. permissible winding temperature +85°C</p> <p>Mechanical data (sleeve bearings)</p> <p>23 Max. permissible speed 14000 rpm</p> <p>24 Axial play 0.05 - 0.15 mm</p> <p>25 Radial play 0.012 mm</p> <p>26 Max. axial load (dynamic) 0.15 N</p> <p>27 Max. force for press fits (static) 15 N</p> <p>28 Max. radial loading, 4 mm from flange 0.4 N</p>	<p>Operating Range</p> <p>n [rpm]</p> <p>15000</p> <p>10000</p> <p>5000</p> <p>0.5 1.0 1.5 2.0 M [mNm]</p> <p>0.1 0.2 0.3 0.4 0.5 I [A]</p> <p>1.5 W</p> <p>256101</p>	<p>Comments</p> <p> Continuous operation In observation of above listed thermal resistance (lines 17 and 18) the maximum permissible winding temperature will be reached during continuous operation at 25°C ambient. = Thermal limit.</p> <p> Short term operation The motor may be briefly overloaded (recurring).</p> <p>— Assigned power rating</p>

Other specifications	maxon Modular System	Overview on page 16 - 21
<p>29 Number of pole pairs 1</p> <p>30 Number of commutator segments 7</p> <p>31 Weight of motor 10 g</p> <p>Values listed in the table are nominal. Explanation of the figures on page 49.</p>	<p>Planetary Gearhead \varnothing10 mm 0.005 - 0.1 Nm Page 214</p> <p>Planetary Gearhead \varnothing10 mm 0.01 - 0.15 Nm Page 215</p> <p>Recommended Electronics: LSC 30/2 Page 276 Notes 18</p>	<p>Encoder MR 16 CPT, 2 channels Page 252</p> <p>Encoder MR 64 - 256 CPT, 2 channels Page 253</p> <p>Encoder MEnc \varnothing10 mm 12 CPT, 2 channels Page 269</p>