

S 2332 Ø32 mm, Graphite Brushes, 15 Watt, CE approved

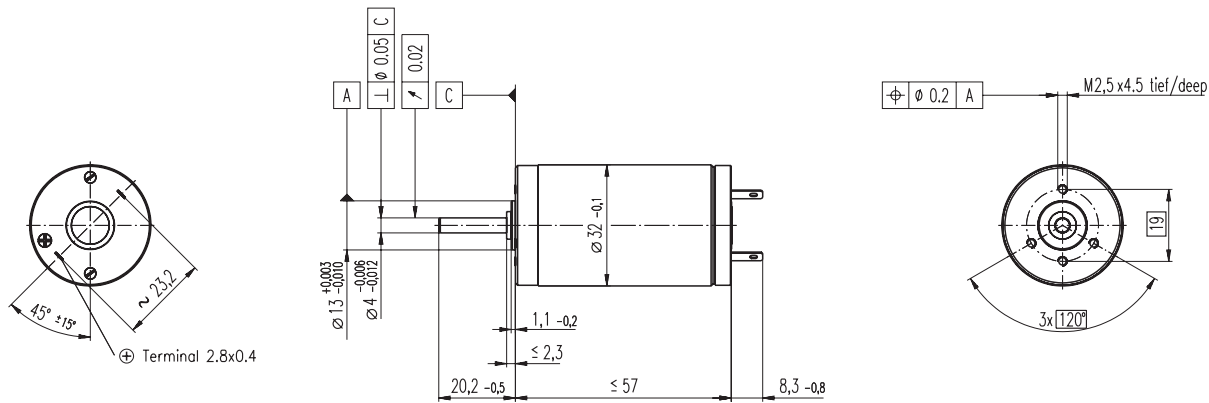

M 1:2

- Stock program
- Standard program
- Special program (on request)

Order Number

2332. ... -12.216-200 (Insert winding number)

Winding number

960	963	964	965	966	967	968	969	970	971	972	973
-----	-----	-----	-----	-----	-----	-----	-----	-----	-----	-----	-----

Motor Data

Values at nominal voltage		960	963	964	965	966	967	968	969	970	971	972	973
1	Nominal voltage	Volt	6.0	9.0	12.0	12.0	12.0	18.0	24.0	30.0	36.0	42.0	48.0
2	No load speed	rpm	5810	5310	6650	5870	4880	5380	5750	6000	5710	5270	4860
3	No load current	mA	110	63.9	65.0	54.6	42.4	32.1	26.3	22.3	17.3	13.3	10.4
4	Nominal speed	rpm	4560	3780	5040	4230	3250	3880	4280	4530	4250	3790	3370
5	Nominal torque (max. continuous torque)	mNm	13.2	22.7	24.3	25.9	26.5	28.6	29.1	28.9	29.3	29.2	29.3
6	Nominal current (max. continuous current)	A	1.50	1.50	1.50	1.40	1.19	0.939	0.763	0.633	0.508	0.399	0.323
7	Stall torque	mNm	89.1	91.1	116	104	85.6	109	119	122	118	106	97.1
8	Starting current	A	9.45	5.79	6.87	5.42	3.72	3.46	3.02	2.59	1.97	1.41	1.04
9	Max. efficiency	%	73	77	79	79	78	81	82	82	82	81	81
Characteristics			960	963	964	965	966	967	968	969	970	971	972
10	Terminal resistance	Ω	0.635	1.56	1.75	2.21	3.22	5.21	7.94	11.6	18.2	29.8	46.1
11	Terminal inductance	mH	0.0883	0.246	0.283	0.363	0.526	0.985	1.54	2.22	3.53	5.64	
12	Torque constant	mNm / A	9.43	15.7	16.9	19.1	23.0	31.5	39.3	47.2	59.6	75.3	
13	Speed constant	rpm / V	1010	607	566	500	415	303	243	202	160	127	
14	Speed / torque gradient	rpm / mNm	68.3	60.0	58.7	57.9	58.2	50.2	49.0	49.6	49.1	50.3	
15	Mechanical time constant	ms	23.6	17.2	16.4	16.0	15.5	14.6	14.3	14.1	14.0	13.9	
16	Rotor inertia	gcm ²	33.0	27.4	26.7	26.4	25.5	27.9	27.8	27.2	27.1	26.4	

Specifications

Thermal data		
17	Thermal resistance housing-ambient	12.5 K / W
18	Thermal resistance winding-housing	1.9 K / W
19	Thermal time constant winding	10.9 s
20	Thermal time constant motor	1440 s
21	Ambient temperature	-20 ... +100°C
22	Max. permissible winding temperature	+125°C
Mechanical data (ball bearings)		
23	Max permissible speed	9200 rpm
24	Axial play	0.5 - 0.15 mm
25	Radial play	0.025 mm
26	Max. axial load (dynamic)	5.6 N
27	Max. force for press fits (static)	113 N
28	Max. radial loading, 5 mm from flange	28 N

Other specifications

29	Number of pole pairs	1
30	Number of commutator segments	13
31	Weight of motor	230 g

Values listed in the table are nominal.
Explanation of the figures on page 49.

Option

Sleeve bearings in place of ball bearings
Pigtails in place of terminals

Operating Range

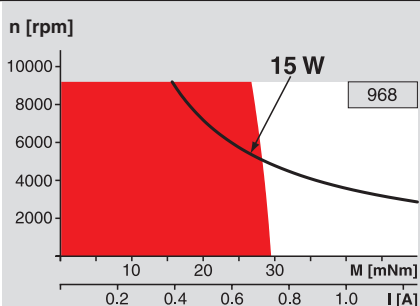

Comments

- Continuous operation**
In observation of above listed thermal resistance (lines 17 and 18) the maximum permissible winding temperature will be reached during continuous operation at 25°C ambient.
= Thermal limit.
- Short term operation**
The motor may be briefly overloaded (recurring).
- Assigned power rating**

maxon Modular System

Overview on page 16 - 21

Planetary Gearhead
Ø32 mm
0.4 - 2.0 Nm
Page 237

Planetary Gearhead
Ø32 mm
0.75 - 4.5 Nm
Page 238

