

S 2326 $\varnothing 26$ mm, Graphite Brushes, 6 Watt, C€ approved

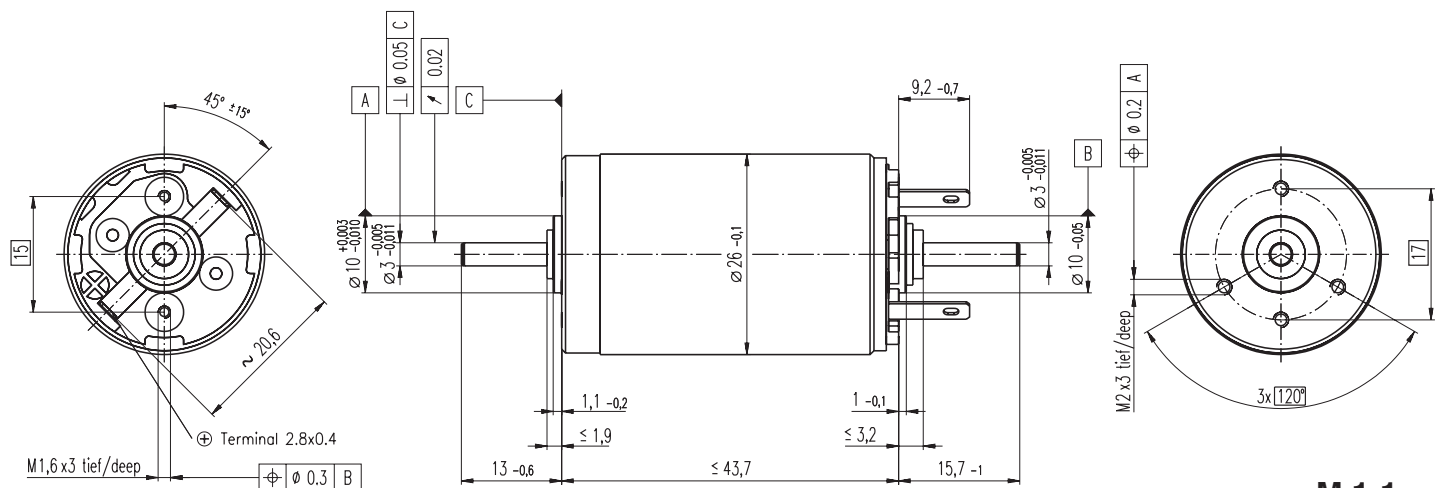

M 1:1

- █ Stock program
- Standard program
- Special program (on request)

Order Number

2326. ... -52.236-200 (Insert winding number)

Winding number	930	933	934	948	936	944	937	938	945	939	946	940	941	942	949
----------------	-----	-----	-----	-----	-----	-----	-----	-----	-----	-----	-----	-----	-----	-----	-----

Motor Data

Values at nominal voltage			3.0	7.2	9.0	12.0	12.0	12.0	15.0	18.0	18.0	24.0	24.0	30.0	36.0	42.0	48.0
1	Nominal voltage	Volt	3.0	7.2	9.0	12.0	12.0	12.0	15.0	18.0	18.0	24.0	24.0	30.0	36.0	42.0	48.0
2	No load speed	rpm	5080	9270	9460	10700	8110	7770	8460	8240	8010	8660	7970	8780	8850	8380	6440
3	No load current	mA	114	101	82.6	72.9	50.0	47.4	42.3	34.0	32.7	27.2	24.4	22.2	18.7	14.9	9.21
4	Nominal speed	rpm	2980	6760	6870	8140	5640	5120	6020	5790	5440	6220	5440	6330	6360	5870	3820
5	Nominal torque (max. continuous torque)	mNm	7.38	10.1	11.4	11.3	12.3	11.5	12.3	12.4	11.8	12.3	12.0	12.3	12.0	12.0	12.0
6	Nominal current (max. continuous current)	A	1.50	1.50	1.36	1.15	0.936	0.839	0.781	0.636	0.592	0.498	0.448	0.403	0.332	0.269	0.180
7	Stall torque	mNm	20.9	42.5	45.7	51.7	42.7	35.1	44.4	43.0	38.0	44.7	38.7	44.9	43.6	40.7	29.9
8	Starting current	A	3.96	5.91	5.17	4.92	3.09	2.44	2.68	2.10	1.81	1.72	1.37	1.40	1.14	0.866	0.43
9	Max. efficiency	%	64	73	75	76	75	73	76	76	75	76	75	77	76	76	73
Characteristics			0.758	1.22	1.74	2.44	3.88	4.92	5.60	8.56	9.96	14.0	17.5	21.4	31.5	48.5	112
10	Terminal resistance	Ω	0.758	1.22	1.74	2.44	3.88	4.92	5.60	8.56	9.96	14.0	17.5	21.4	31.5	48.5	112
11	Terminal inductance	mH	0.0652	0.121	0.183	0.258	0.447	0.484	0.644	0.980	1.03	1.58	1.86	2.41	3.41	5.17	11.4
12	Torque constant	mNm / A	5.28	7.19	8.85	10.5	13.8	14.4	16.6	20.5	21.0	26.0	28.2	32.1	38.2	47.0	69.7
13	Speed constant	rpm / V	1810	1330	1080	909	691	664	576	467	455	367	339	298	250	203	137
14	Speed / torque gradient	rpm / mNm	260	225	213	211	194	227	194	195	215	197	210	199	207	210	220
15	Mechanical time constant	ms	30.2	22.6	21.0	20.0	19.3	19.3	18.8	18.5	18.6	18.3	18.4	18.2	18.2	18.2	18.2
16	Rotor inertia	gcm ²	11.1	9.58	9.43	9.04	9.47	8.11	9.25	9.05	8.25	8.86	8.34	8.72	8.40	8.28	7.93

Specifications

Thermal data			17 K / W	2.4 K / W	5.72 s	926 s	-20 ... +100°C	+125°C
17	Thermal resistance housing-ambient		17 K / W					
18	Thermal resistance winding-housing		2.4 K / W					
19	Thermal time constant winding		5.72 s					
20	Thermal time constant motor		926 s					
21	Ambient temperature		-20 ... +100°C					
22	Max. permissible winding temperature		+125°C					
Mechanical data (ball bearings)			11000 rpm	0.5 - 0.15 mm	0.025 mm	2.8 N	64 N	700 N
23	Max permissible speed		11000 rpm					
24	Axial play		0.5 - 0.15 mm					
25	Radial play		0.025 mm					
26	Max. axial load (dynamic)		2.8 N					
27	Max. force for press fits (static)		64 N					
28	Max. force for press fits (static) (static, shaft supported)		700 N					
28	Max. radial loading, 5 mm from flange		14 N					

Other specifications

29	Number of pole pairs	1
30	Number of commutator segments	11
31	Weight of motor	109 g

Values listed in the table are nominal.
Explanation of the figures on page 49.

Option

Sleeve bearings in place of ball bearings
Pigtails in place of terminals

Operating Range

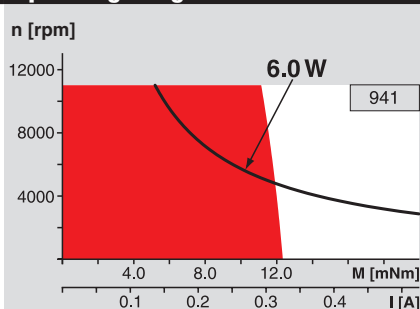

Comments

- █ **Continuous operation**
In observation of above listed thermal resistance (lines 17 and 18) the maximum permissible winding temperature will be reached during continuous operation at 25°C ambient.
= Thermal limit.
- Short term operation**
The motor may be briefly overloaded (recurring).
- **Assigned power rating**

maxon Modular System

Spur Gearhead
 $\varnothing 38$ mm
0.1 - 0.6 Nm
Page 243

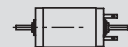
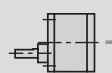

Overview on page 16 - 21

- Encoder Enc**
22 mm
100 CPT, 2 channels
Page 260
- Encoder HEDS 5540**
500 CPT,
3 channels
Page 263
- Encoder HEDL 5540**
500 CPT,
3 channels
Page 264
- DC-Tacho DCT**
 $\varnothing 22$ mm
0.52 V
Page 271