

# EC 45 flat $\varnothing 45$ mm, brushless, 50 Watt

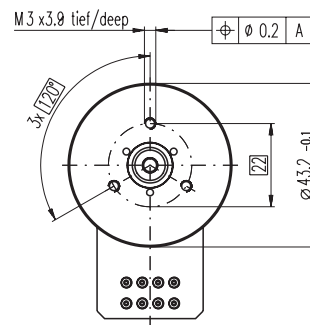
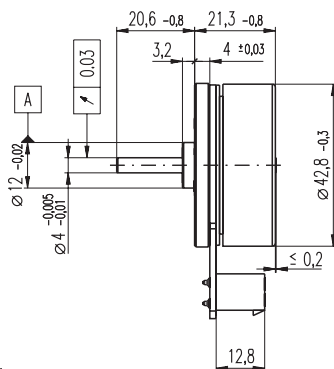
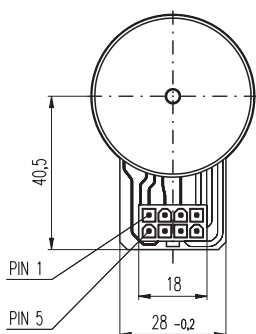

Connector:  
39-28-1083  
MOLEX

M 1:2

- Stock program
- Standard program
- Special program (on request)

## Order Number

with hall sensors

339285	251601	339286	339287
--------	--------	--------	--------

## Motor Data

Values at nominal voltage		339285	251601	339286	339287	
1	Nominal voltage	V	18.0	24.0	24.0	36.0
2	No load speed	rpm	6710	6700	4700	3360
3	No load current	mA	294	201	116	46.9
4	Nominal speed	rpm	5250	5260	3410	2320
5	Nominal torque (max. continuous torque)	mNm	96.9	84.3	64.2	94.3
6	Nominal current (max. continuous current)	A	3.54	2.36	1.32	0.861
7	Stall torque	mNm	1100	822	337	488
8	Starting current	A	43.6	24.5	7.10	4.86
9	Max. efficiency	%	84.5	83	77	82
<b>Characteristics</b>						
10	Terminal resistance phase to phase	$\Omega$	0.413	0.978	3.38	7.41
11	Terminal inductance phase to phase	mH	0.322	0.573	1.15	5.15
12	Torque constant	mNm / A	25.1	33.5	47.5	101
13	Speed constant	rpm / V	380	285	201	95.0
14	Speed / torque gradient	rpm / mNm	6.24	8.32	14.3	7.00
15	Mechanical time constant	ms	8.82	11.8	20.3	9.90
16	Rotor inertia	gcm <sup>2</sup>	135	135	135	135

## Specifications

<b>Thermal data</b>		
17	Thermal resistance housing-ambient	4.25 K / W
18	Thermal resistance winding-housing	4.5 K / W
19	Thermal time constant winding	16.6 s
20	Thermal time constant motor	212 s
21	Ambient temperature	-40 ... +100°C
22	Max. permissible winding temperature	+125°C
<b>Mechanical data (preloaded ball bearings)</b>		
23	Max. permissible speed	10000 rpm
24	Axial play at axial load < 4.0 N	0 mm
	> 4.0 N	0.14 mm
25	Radial play	preloaded
26	Max. axial load (dynamic)	3.8 N
27	Max. force for press fits (static) (static, shaft supported)	50 N
28	Max. radial loading, 7.5 mm from flange	5.5 N

## Other specifications

29	Number of pole pairs	8
30	Number of phases	3
31	Weight of motor	110 g

Values listed in the table are nominal.

## Connection

Pin 1	Hall sensor 1*
Pin 2	Hall sensor 2*
Pin 3	4.5 ... 18 VDC
Pin 4	Motor winding 3
Pin 5	Hall sensor 3*
Pin 6	GND
Pin 7	Motor winding 1
Pin 8	Motor winding 2

\*internal pull-up (7 ... 13 k $\Omega$ ) on pin 3

Wiring diagram for Hall sensors see page 29

## Cable

Connection cable Universal, L = 500 mm	339380
Connection cable to EPOS, L = 500 mm	354045

## Operating Range

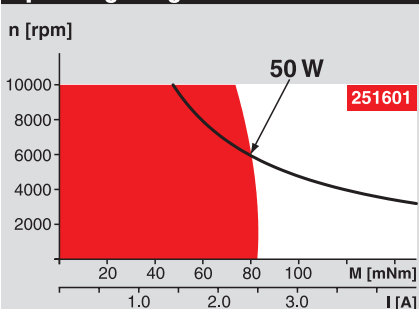

## Comments

**Continuous operation**  
In observation of above listed thermal resistance (lines 17 and 18) the maximum permissible winding temperature will be reached during continuous operation at 25°C ambient.  
= Thermal limit.

**Short term operation**  
The motor may be briefly overloaded (recurring).

— **Assigned power rating**

## maxon Modular System

Overview on page 16 - 21

### Planetary Gearhead

$\varnothing 42$  mm  
3 - 15 Nm  
Page 244

### Spur Gearhead

$\varnothing 45$  mm  
0.5 - 2.0 Nm  
Page 246

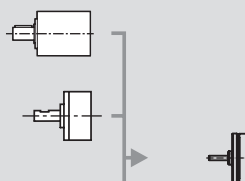

## Recommended Electronics:

DECS 50/5	Page 284
DEC 24/3	285
DEC 50/5	285
DECV 50/5	286
EPOS 24/1	294
EPOS 24/5	294
EPOS P 24/5	297
Notes	20