

EC 20 flat Ø20 mm, brushless, 3 Watt

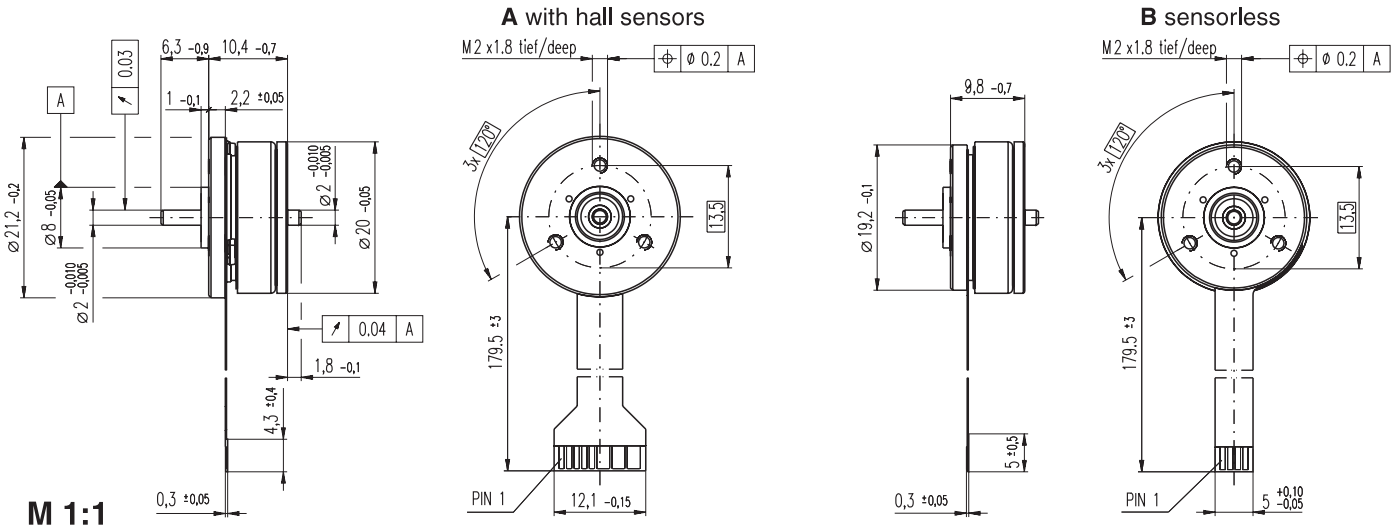

- Stock program
- Standard program
- Special program (on request)

Order Number

	A with hall sensors	B sensorless
351098	351099	351100
339255	241916	339257
		339258

Motor Data

Values at nominal voltage		6.0	9.0	12.0	24.0	
1	Nominal voltage	V	6.0	9.0	12.0	24.0
2	No load speed	rpm	8960	9630	9370	9310
3	No load current	mA	62.5	44.9	33.1	16.2
4	Nominal speed	rpm	3160	4230	3530	3840
5	Nominal torque (max. continuous torque)	mNm	3.07	3.91	3.16	3.67
6	Nominal current (max. continuous current)	A	0.548	0.470	0.292	0.163
7	Stall torque	mNm	5.29	8.04	5.67	7.12
8	Starting current	A	0.900	0.957	0.503	0.309
9	Max. efficiency	%	55	62	56	60
Characteristics						
10	Terminal resistance phase to phase	Ω	6.67	9.40	23.9	77.7
11	Terminal inductance phase to phase	mH	0.639	1.30	2.35	9.80
12	Torque constant	mNm / A	5.88	8.40	11.3	23
13	Speed constant	rpm / V	1620	1140	847	414
14	Speed / torque gradient	rpm / mNm	1840	1270	1790	1400
15	Mechanical time constant	ms	74.1	51.2	72.1	56.2
16	Rotor inertia	gcm ²	3.84	3.84	3.84	3.84

Specifications

Thermal data		
17	Thermal resistance housing-ambient	15.3 K / W
18	Thermal resistance winding-housing	7.5 K / W
19	Thermal time constant winding	3.28 s
20	Thermal time constant motor	25.4 s
21	Ambient temperature	-40 ... +100°C
22	Max. permissible winding temperature	+125°C
Mechanical data (preloaded ball bearings)		
23	Max. permissible speed	15000 rpm
24	Axial play at axial load < 2.0 N	0 mm
	> 2.0 N	0.14 mm
25	Radial play	preloaded
26	Max. axial load (dynamic)	1.8 N
27	Max. force for press fits (static)	10 N
	(static, shaft supported)	200 N
28	Max. radial loading, 5 mm from flange	1.8 N

Operating Range

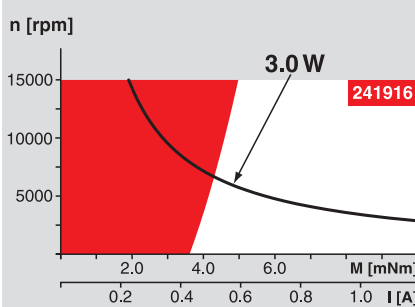

Comments

Continuous operation
In observation of above listed thermal resistance (lines 17 and 18) the maximum permissible winding temperature will be reached during continuous operation at 25°C ambient.
= Thermal limit.

Short term operation
The motor may be briefly overloaded (recurring).

— Assigned power rating

Other specifications		
29	Number of pole pairs	4
30	Number of phases	3
31	Weight of motor	15 g

Values listed in the table are nominal.

Connection	with hall sensors	sensorless
Pin 1	4.5 ... 24 VDC	Motor winding 1
Pin 2	Hall sensor 3	Motor winding 2
Pin 3	Hall sensor 1	Motor winding 3
Pin 4	Hall sensor 2	neutral point
Pin 5	GND	
Pin 6	Motor winding 3	
Pin 7	Motor winding 2	
Pin 8	Motor winding 1	

Adapter	Order number	Order number
see p. 299	220300	220310

Connector	Article number	Article number
AMP	1-487951-1	487951-4
MOLEX	52207-1190	52207-0490
MOLEX	52089-1110	52089-0410

Pin for design with Hall sensors:
FPC, 11 pole, pitch 1.0 mm, top contact style
Wiring diagram for Hall sensors see page 29

maxon Modular System

Overview on page 16 - 21

Spur Gearhead
Ø20.3 mm
0.06 - 0.25 Nm
Page 227

Planetary Gearhead
Ø22 mm
0.5 - 1.0 Nm
Page 230

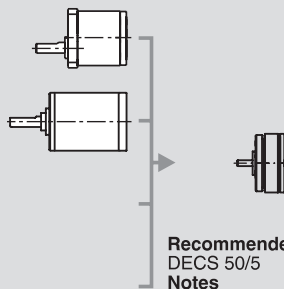

Recommended Electronics:
DECS 50/5 Page 284
Notes 20