

EC 45 4-pol □45 mm, brushless, 200 Watt, CE approved

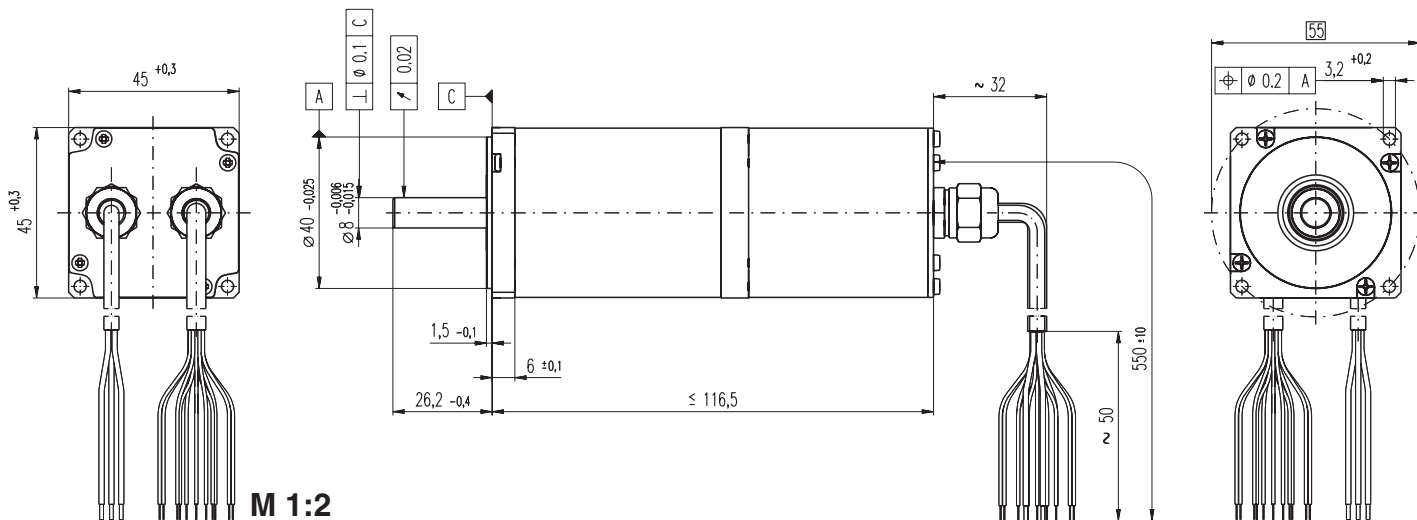

- Stock program
- Standard program
- Special program (on request)

Order Number

	with encoder	266052	252463	252464
--	--------------	--------	--------	--------

Motor Data (provisional)

Values at nominal voltage					
1	Nominal voltage	V	48.0	48.0	48.0
2	No load speed	rpm	8730	6120	4370
3	No load current	mA	473	261	153
4	Nominal speed	rpm	8150	5580	3830
5	Nominal torque (max. continuous torque)	mNm	237	297	308
6	Nominal current (max. continuous current)	A	4.93	4.16	3.04
7	Stall torque	mNm	4420	4070	2890
8	Starting current	A	84.8	54.7	27.7
9	Max. efficiency	%	86	87	86

Characteristics

10	Terminal resistance phase to phase	Ω	0.566	0.878	1.73
11	Terminal inductance phase to phase	mH	0.172	0.350	0.686
12	Torque constant	mNm / A	52.2	74.5	104
13	Speed constant	rpm / V	183	128	91.6
14	Speed / torque gradient	rpm / mNm	1.99	1.51	1.52
15	Mechanical time constant	ms	4.16	3.16	3.18
16	Rotor inertia	gcm ²	200	200	200

Specifications

Thermal data		
17	Thermal resistance housing-ambient	3.1 K / W
18	Thermal resistance winding-housing	1.0 K / W
19	Thermal time constant winding	31.8 s
20	Thermal time constant motor	1550 s
21	Ambient temperature	-10 ... +100°C
22	Max. permissible winding temperature	+125°C
Mechanical data (preloaded ball bearings)		
23	Max. permissible speed	10000 rpm
24	Axial play at axial load < 20 N	0 mm
	> 20 N	max. 0.14 mm
25	Radial play	preloaded
26	Max. axial load (dynamic)	20 N
27	Max. force for press fits (static) (static, shaft supported)	170 N
		5000 N
28	Max. radial loading, 5 mm from flange	140 N

Other specifications

29	Number of pole pairs	2
30	Number of phases	3
31	Weight of motor	1000 g
	Protection to	IP54

Values listed in the table are nominal.

Connection Motor (Cable AWG 18)

Cable 1	Motor winding 1
Cable 2	Motor winding 2
Cable 3	Motor winding 3

Option

Temperature monitoring, PTC resistance
R 20°C < 0.3 kΩ
R 130°C = 7.0 ... 35 kΩ

Operating Range

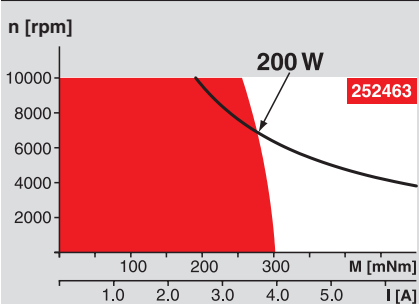

Comments

Continuous operation
In observation of above listed thermal resistance (lines 17 and 18) the maximum permissible winding temperature will be reached during continuous operation at 25°C ambient.
= Thermal limit.

Short term operation
The motor may be briefly overloaded (recurring).

— Assigned power rating

Integrated encoder R35i

Connection Encoder (Cable AWG 26)		
green	(Pin 1)	Channel A
yellow	(Pin 2)	Channel A
red	(Pin 3)	Channel B
blue	(Pin 4)	Channel B
pink	(Pin 5)	Channel I (Index)
grey	(Pin 6)	Channel I (Index)
violet	(Pin 7)	Commutation signal S 1
red/blue	(Pin 8)	GND 2
black	(Pin 9)	Commutation signal S 2
white/green	(Pin 10)	V _{CC} 2
grey/pink	(Pin 11)	Commutation signal S 3
	(Pin 12)	n.c.
white	(Pin 13)	V _{CC} 1
brown	(Pin 14)	GND 1

Counts per turn	2048
Number of channels	3
Max. operating frequency (kHz)	200
Supply voltage	5 V ± 5 %
Output signal	RS 422
Phase shift Φ (nominal)	90°e
Logic state width s	min. 45°e
Index pulse width (nominal)	360°e
Operating temperature range	-10 ... +100°C
Moment of inertia	≤ 3.11 gcm ²

Recommended Electronics:

DECS 50/5	Page 284
DEC 50/5	285
DEC 70/10	286
DES 50/5	287
DES 70/10	287
EPOS 70/10	295
EPOS2 50/5	295
Notes	20