

EC 16 Ø16 mm, brushless, 40 Watt

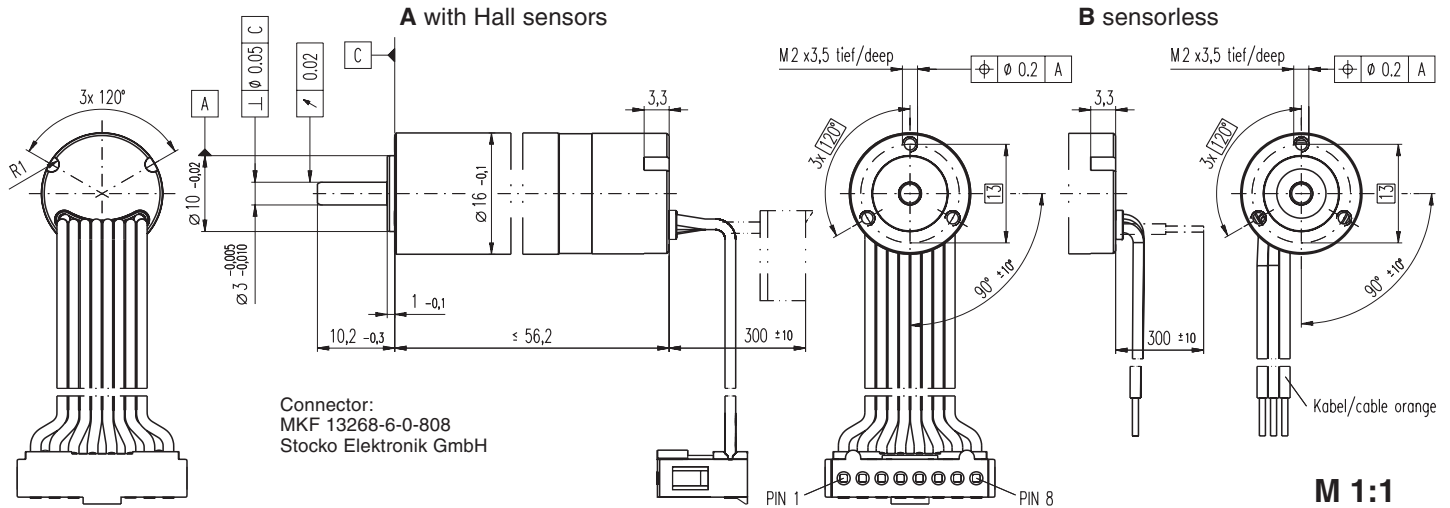

- Stock program
- Standard program
- Special program (on request)

Order Number

A with Hall sensors
B sensorless

232242	262860	232241	262862
235689	262864	235686	262866

Motor Data

Values at nominal voltage						
1	Nominal voltage	V	12.0	18.0	24.0	32.0
2	No load speed	rpm	35800	40300	41400	41400
3	No load current	mA	358	284	222	166
4	Nominal speed	rpm	32100	36700	37900	37900
5	Nominal torque (max. continuous torque)	mNm	13.3	13.4	13.9	13.8
6	Nominal current (max. continuous current)	A	4.51	3.41	2.71	2.03
7	Stall torque	mNm	141	166	184	183
8	Starting current	A	44.5	39.3	33.5	24.9
9	Max. efficiency	%	83	84	85	85
Characteristics						
10	Terminal resistance phase to phase	Ω	0.269	0.458	0.716	1.28
11	Terminal inductance phase to phase	mH	0.0140	0.0249	0.0420	0.0746
12	Torque constant	mNm / A	3.18	4.23	5.50	7.33
13	Speed constant	rpm / V	3010	2260	1740	1300
14	Speed / torque gradient	rpm / mNm	255	244	226	228
15	Mechanical time constant	ms	3.39	3.25	3.01	3.03
16	Rotor inertia	gcm ²	1.27	1.27	1.27	1.27

Specifications

Thermal data		
17	Thermal resistance housing-ambient	10.3 K / W
18	Thermal resistance winding-housing	1.2 K / W
19	Thermal time constant winding	2.08 s
20	Thermal time constant motor	299 s
21	Ambient temperature	-20 ... +100°C
22	Max. permissible winding temperature	+125°C
Mechanical data (preloaded ball bearings)		
23	Max. permissible speed	50000 rpm
24	Axial play at axial load < 3.5 N	0 mm
	> 3.5 N	max. 0.14 mm preloaded
25	Radial play	preloaded
26	Max. axial load (dynamic)	3 N
27	Max. force for press fits (static) (static, shaft supported)	40 N
28	Max. radial loading, 5 mm from flange	10 N
Other specifications		
29	Number of pole pairs	1
30	Number of phases	3
31	Weight of motor	58 g

Values listed in the table are nominal.

Connection A

brown	Motor winding 1	Pin 1
red	Motor winding 2	Pin 2
orange	Motor winding 3	Pin 3
yellow	V _{Hall} 4.5 ... 24 VDC	Pin 4
green	GND	Pin 5
blue	Hall sensor 1	Pin 6
violet	Hall sensor 2	Pin 7
grey	Hall sensor 3	Pin 8

Connection B (Cable AWG 24)

brown	Motor winding 1
red	Motor winding 2
orange	Motor winding 3

Wiring diagram for Hall sensors see page 27

Operating Range

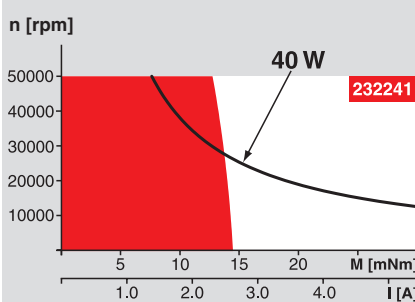

Comments

Continuous operation
In observation of above listed thermal resistance (lines 17 and 18) the maximum permissible winding temperature will be reached during continuous operation at 25°C ambient.
= Thermal limit.

Short term operation
The motor may be briefly overloaded (recurring).

— **Assigned power rating**

maxon Modular System

Planetary Gearhead
Ø22 mm
0.5 - 2.0 Nm
Page 232

Overview on page 16 - 21

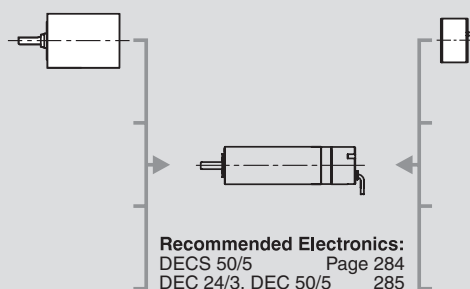

Recommended Electronics:

DECS 50/5	Page 284
DEC 24/3, DEC 50/5	285
DECV 50/5	286
DES 50/5	287
EPOS 24/1	294
EPOS 24/5	294
EPOS2 50/5	295
EPOS P 24/5	297
Notes	20

for type A:
Encoder MR
128 / 256 / 512 CPT,
Page 257