

EC 16 \varnothing 16 mm, brushless, 15 Watt

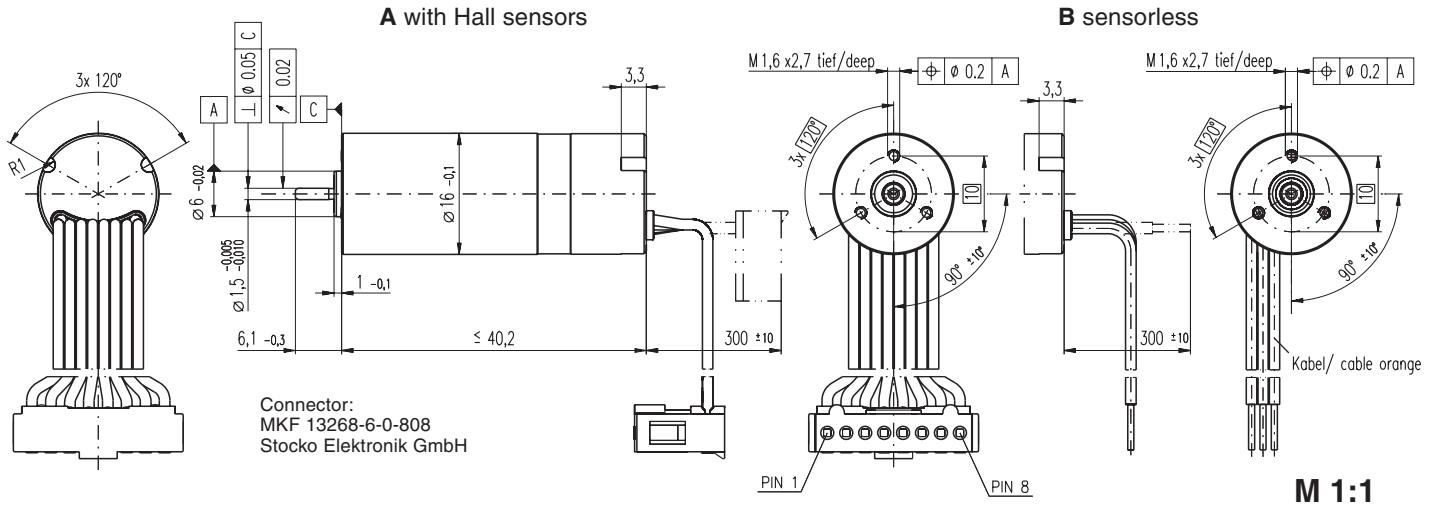

- Stock program
- Standard program
- Special program (on request)

Order Number

A with Hall sensors
B sensorless

266521	236918	266519	236917
266523	236922	266522	236921

Motor Data

Values at nominal voltage						
1	Nominal voltage	V	12.0	18.0	24.0	32.0
2	No load speed	rpm	33900	37400	39200	38400
3	No load current	mA	234	179	144	105
4	Nominal speed	rpm	28200	31700	33700	32800
5	Nominal torque (max. continuous torque)	mNm	4.96	4.76	4.89	4.77
6	Nominal current (max. continuous current)	A	1.71	1.22	0.984	0.707
7	Stall torque	mNm	31.2	33.1	36.9	34.4
8	Starting current	A	9.47	7.38	6.47	4.43
9	Max. efficiency	%	72	72	73	72
Characteristics						
10	Terminal resistance phase to phase	Ω	1.27	2.44	3.71	7.22
11	Terminal inductance phase to phase	mH	0.0350	0.0648	0.105	0.194
12	Torque constant	mNm / A	3.30	4.48	5.71	7.77
13	Speed constant	rpm / V	2900	2130	1670	1230
14	Speed / torque gradient	rpm / mNm	1110	1160	1090	1140
15	Mechanical time constant	ms	8.75	9.10	8.53	8.98
16	Rotor inertia	gcm ²	0.750	0.750	0.750	0.750

Specifications

Thermal data		
17	Thermal resistance housing-ambient	15.6 K / W
18	Thermal resistance winding-housing	1.8 K / W
19	Thermal time constant winding	1.24 s
20	Thermal time constant motor	265 s
21	Ambient temperature	-20 ... +100°C
22	Max. permissible winding temperature	+125°C
Mechanical data (preloaded ball bearings)		
23	Max. permissible speed	50000 rpm
24	Axial play at axial load < 3.5 N	0 mm
	> 3.5 N	max. 0.14 mm preloaded
25	Radial play	preloaded
26	Max. axial load (dynamic)	3 N
27	Max. force for press fits (static)	40 N
	(static, shaft supported)	250 N
28	Max. radial loading, 5 mm from flange	10 N
Other specifications		
29	Number of pole pairs	1
30	Number of phases	3
31	Weight of motor	34 g

Values listed in the table are nominal.

Connection A

brown	Motor winding 1	Pin 1
red	Motor winding 2	Pin 2
orange	Motor winding 3	Pin 3
yellow	V _{Hall} 4.5 ... 24 VDC	Pin 4
green	GND	Pin 5
blue	Hall sensor 1	Pin 6
violet	Hall sensor 2	Pin 7
grey	Hall sensor 3	Pin 8

Connection B (Cable AWG 24)

brown	Motor winding 1
red	Motor winding 2
orange	Motor winding 3

Wiring diagram for Hall sensors see page 27

Operating Range

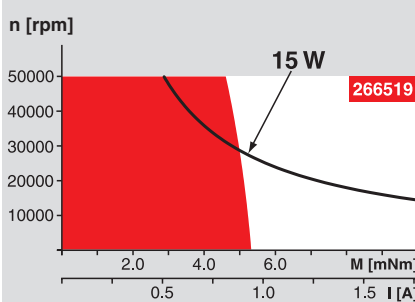

Comments

Continuous operation
In observation of above listed thermal resistance (lines 17 and 18) the maximum permissible winding temperature will be reached during continuous operation at 25°C ambient.
= Thermal limit.

Short term operation
The motor may be briefly overloaded (recurring).

— Assigned power rating

maxon Modular System

Planetary Gearhead
 \varnothing 16 mm
0.1 - 0.3 Nm
Page 224

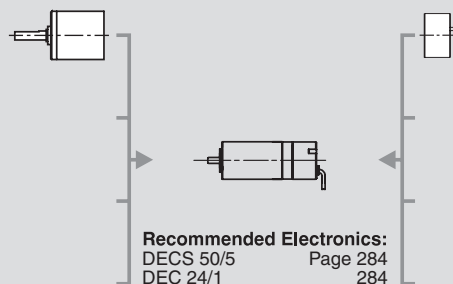

Recommended Electronics:

DECS 50/5	Page 284
DEC 24/1	284
DEC 24/3	285
DEC 50/5	285
DECV 50/5	286
DES 50/5	287
EPOS 24/1	294
Notes	20

Overview on page 16 - 21

for type A:
Encoder MR
128 / 256 / 512 CPT,
Page 257