

RE-max 24 Ø24 mm, Graphite Brushes, 11 Watt

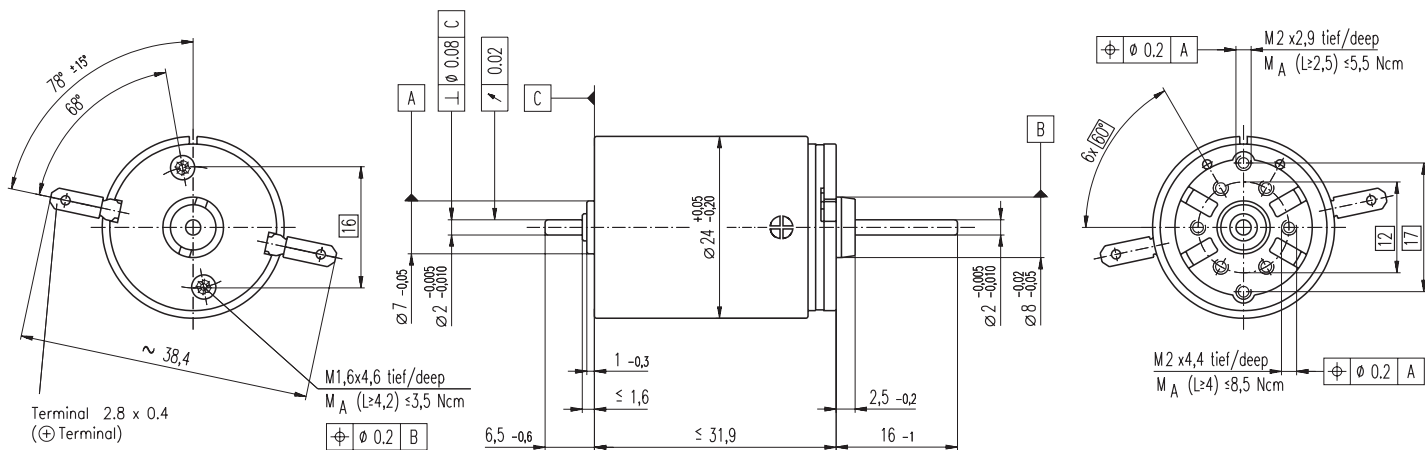

M 1:1

- Stock program
- Standard program
- Special program (on request)

Order Number

222048 **222049** 222050 222051 222052 222053 222054 **222055** 222056 222057 **222058** 222059

Motor Data

Values at nominal voltage		222048	222049	222050	222051	222052	222053	222054	222055	222056	222057	222058	222059	
1	Nominal voltage	V	9.0	12.0	15.0	18.0	18.0	24.0	24.0	36.0	42.0	48.0	48.0	
2	No load speed	rpm	8190	7540	8290	8870	8000	9310	7540	9120	8600	7410	5250	4730
3	No load current	mA	45.6	31.0	27.7	25.0	22.1	19.8	15.5	12.9	10.3	7.60	5.15	4.59
4	Nominal speed	rpm	6640	5870	6650	7240	6330	7670	5850	7450	6920	5690	3470	2960
5	Nominal torque (max. continuous torque)	mNm	10.8	12.4	12.4	12.3	12.3	12.1	12.2	12.1	12.0	12.0	12.1	
6	Nominal current (max. continuous current)	A	1.08	0.853	0.752	0.666	0.598	0.516	0.421	0.335	0.270	0.204	0.144	0.131
7	Stall torque	mNm	57.7	56.9	63.6	67.7	59.5	69.3	55.3	66.6	62.0	52.4	35.7	32.8
8	Starting current	A	5.55	3.78	3.71	3.52	2.79	2.83	1.83	1.78	1.34	0.855	0.414	0.343
9	Max. efficiency	%	83	83	83	84	83	84	83	84	83	82	79	78
Characteristics														
10	Terminal resistance	Ω	1.62	3.18	4.05	5.11	6.44	8.47	13.1	20.2	31.3	56.2	116	140
11	Terminal inductance	mH	0.0735	0.154	0.200	0.251	0.309	0.406	0.618	0.952	1.45	2.56	5.06	6.22
12	Torque constant	mNm / A	10.4	15.1	17.2	19.2	21.3	24.4	30.1	37.4	46.3	61.3	86.3	95.6
13	Speed constant	rpm / V	919	634	557	497	448	391	317	255	206	156	111	99.8
14	Speed / torque gradient	rpm / mNm	143	134	131	132	135	135	138	138	140	143	149	146
15	Mechanical time constant	ms	5.96	5.90	5.88	5.89	5.91	5.92	5.92	5.93	5.96	5.97	6.03	6.00
16	Rotor inertia	gcm ²	3.97	4.22	4.28	4.26	4.17	4.17	4.11	4.11	4.07	4.00	3.88	3.92

Specifications

- Thermal data**
- 17 Thermal resistance housing-ambient 24 K / W
 - 18 Thermal resistance winding-housing 5.1 K / W
 - 19 Thermal time constant winding 8.26 s
 - 20 Thermal time constant motor 852 s
 - 21 Ambient temperature -30 ... +85°C
 - 22 Max. permissible winding temperature +125°C
- Mechanical data (sleeve bearings)**
- 23 Max. permissible speed 9800 rpm
 - 24 Axial play 0.05 - 0.15 mm
 - 25 Radial play 0.012 mm
 - 26 Max. axial load (dynamic) 1 N
 - 27 Max. force for press fits (static) (static, shaft supported) 80 N / 440 N
 - 28 Max. radial loading, 5 mm from flange 2.8 N
- Mechanical data (ball bearings)**
- 23 Max. permissible speed 9800 rpm
 - 24 Axial play 0.05 - 0.15 mm
 - 25 Radial play 0.025 mm
 - 26 Max. axial load (dynamic) 3.3 N
 - 27 Max. force for press fits (static) (static, shaft supported) 45 N / 440 N
 - 28 Max. radial loading, 5 mm from flange 12.3 N
- Other specifications**
- 29 Number of pole pairs 1
 - 30 Number of commutator segments 9
 - 31 Weight of motor 71 g

Values listed in the table are nominal.
Explanation of the figures on page 49.

Option

- Ball bearings in place of sleeve bearings
- Pigtails in place of terminals

Operating Range

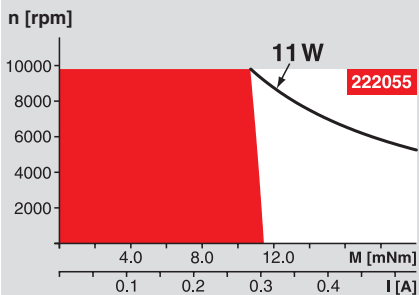

Comments

- Continuous operation**
In observation of above listed thermal resistance (lines 17 and 18) the maximum permissible winding temperature will be reached during continuous operation at 25°C ambient.
= Thermal limit.
- Short term operation**
The motor may be briefly overloaded (recurring).
- Assigned power rating**

maxon Modular System

- Planetary Gearhead**
Ø22 mm
0.5 - 2.0 Nm
Page 231
- Spur Gearhead**
Ø38 mm
0.1 - 0.6 Nm
Page 243

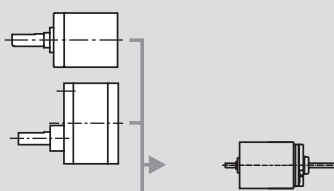

- Recommended Electronics:**
- LSC 30/2 Page 276
 - ADS 50/5 276
 - ADS_E 50/5 277
 - EPOS 24/1 294
 - Notes 18

Overview on page 16 - 21

- Encoder MR**
32 CPT,
2 / 3 channels
Page 255
- Encoder MR**
128 / 256 / 512 CPT,
2 / 3 channels
Page 256