

RE-max 24 Ø24 mm, Precious Metal Brushes CLL, 6.5 Watt

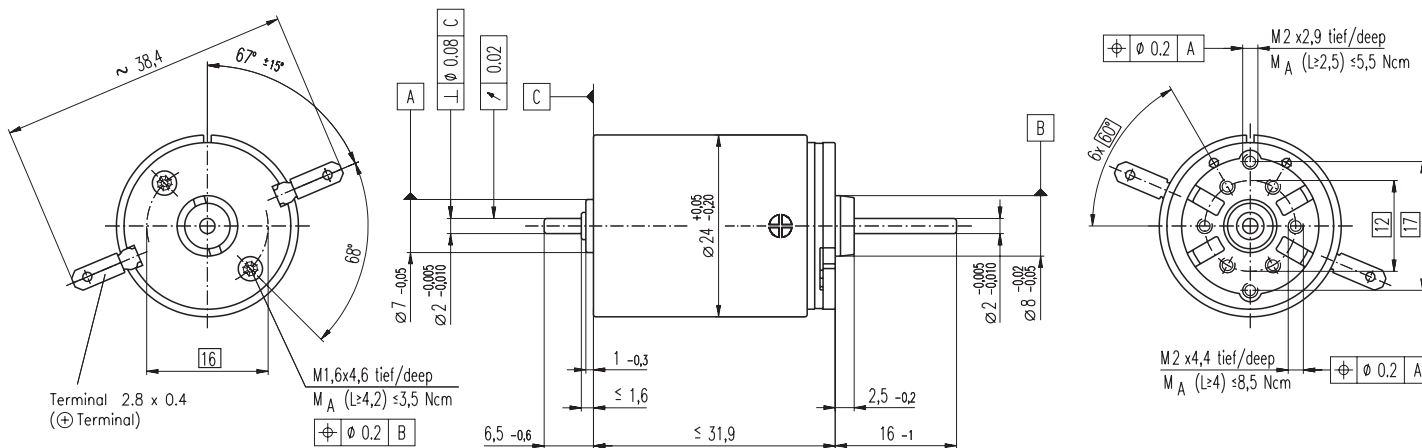

M 1:1

- Stock program
- Standard program
- Special program (on request)

Order Number

220425	220426	220427	220428	220429	220430	220431	220432	220433	220434	220435	220437
--------	--------	--------	--------	--------	--------	--------	--------	--------	--------	--------	--------

Motor Data

Values at nominal voltage		220425	220426	220427	220428	220429	220430	220431	220432	220433	220434	220435	220437	
1	Nominal voltage	V	6.0	9.0	9.0	12.0	12.0	15.0	18.0	24.0	30.0	36.0	48.0	48.0
2	No load speed	rpm	5480	5680	4990	5930	5350	5840	5670	6100	6160	5580	5280	4770
3	No load current	mA	18.7	13.1	10.9	10.5	9.03	8.17	6.54	5.44	4.42	3.19	2.22	1.92
4	Nominal speed	rpm	4240	4250	3570	4520	3920	4410	4230	4660	4720	4110	3790	3280
5	Nominal torque (max. continuous torque)	mNm	8.56	10.6	10.7	10.7	10.6	10.6	10.5	10.5	10.4	10.3	10.1	10.2
6	Nominal current (max. continuous current)	A	0.840	0.716	0.636	0.565	0.504	0.439	0.354	0.284	0.228	0.171	0.119	0.109
7	Stall torque	mNm	37.9	42.4	38.0	45.0	39.6	43.2	41.4	44.4	44.3	39.3	35.7	32.8
8	Starting current	A	3.65	2.81	2.21	2.34	1.86	1.77	1.37	1.19	0.957	0.641	0.414	0.343
9	Max. efficiency	%	86	87	87	87	87	87	87	87	87	86	86	
Characteristics			220425	220426	220427	220428	220429	220430	220431	220432	220433	220434	220435	220437
10	Terminal resistance	Ω	1.64	3.20	4.07	5.13	6.46	8.48	13.1	20.2	31.3	56.2	116	140
11	Terminal inductance	mH	0.0735	0.154	0.200	0.251	0.309	0.406	0.618	0.952	1.45	2.56	5.06	6.22
12	Torque constant	mNm / A	10.4	15.1	17.2	19.2	21.3	24.4	30.1	37.4	46.3	61.3	86.3	95.6
13	Speed constant	rpm / V	919	634	557	497	448	391	317	255	206	156	111	99.8
14	Speed / torque gradient	rpm / mNm	145	134	132	133	136	136	138	138	140	143	149	146
15	Mechanical time constant	ms	6.16	6.04	6.01	6.02	6.03	6.03	6.03	6.04	6.07	6.08	6.15	6.11
16	Rotor inertia	gcm ²	4.05	4.30	4.35	4.33	4.24	4.25	4.18	4.18	4.14	4.07	3.95	3.99

Specifications

- Thermal data**
- 17 Thermal resistance housing-ambient 24 K / W
 - 18 Thermal resistance winding-housing 5.1 K / W
 - 19 Thermal time constant winding 8.26 s
 - 20 Thermal time constant motor 852 s
 - 21 Ambient temperature -30 ... +65°C
 - 22 Max. permissible winding temperature +85°C
- Mechanical data (sleeve bearings)**
- 23 Max. permissible speed 9500 rpm
 - 24 Axial play 0.05 - 0.15 mm
 - 25 Radial play 0.012 mm
 - 26 Max. axial load (dynamic) 1 N
 - 27 Max. force for press fits (static) (static, shaft supported) 80 N / 440 N
 - 28 Max. radial loading, 5 mm from flange 2.8 N

- Mechanical data (ball bearings)**
- 23 Max. permissible speed 9500 rpm
 - 24 Axial play 0.05 - 0.15 mm
 - 25 Radial play 0.025 mm
 - 26 Max. axial load (dynamic) 3.3 N
 - 27 Max. force for press fits (static) (static, shaft supported) 45 N / 440 N
 - 28 Max. radial loading, 5 mm from flange 12.3 N

- Other specifications**
- 29 Number of pole pairs 1
 - 30 Number of commutator segments 9
 - 31 Weight of motor 71 g
- CLL = Capacitor Long Life

Values listed in the table are nominal.
Explanation of the figures on page 49.

- Option**
- Ball bearings in place of sleeve bearings
 - Pigtails in place of terminals
 - Without CLL

Operating Range

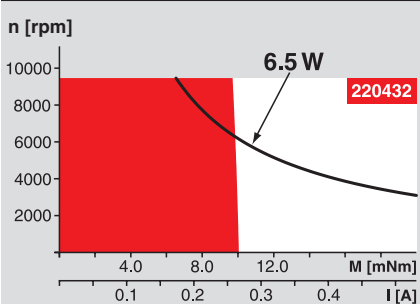

Comments

Continuous operation
In observation of above listed thermal resistance (lines 17 and 18) the maximum permissible winding temperature will be reached during continuous operation at 25°C ambient.
= Thermal limit.

Short term operation
The motor may be briefly overloaded (recurring).

— Assigned power rating

maxon Modular System

- Planetary Gearhead**
Ø22 mm
0.5 - 2.0 Nm
Page 231
- Spur Gearhead**
Ø38 mm
0.1 - 0.6 Nm
Page 243

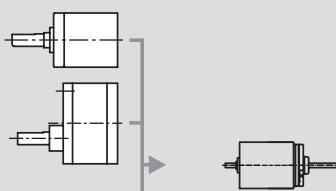

Recommended Electronics:
LSC 30/2 Page 276
EPOS 24/1 Page 294
Notes 18

Overview on page 16 - 21

- Encoder MR**
32 CPT,
2 / 3 channels
Page 255
- Encoder MR**
128 / 256 / 512 CPT,
2 / 3 channels
Page 256