

# RE-max 13 Ø13 mm, Precious Metal Brushes CLL, 2.5 Watt

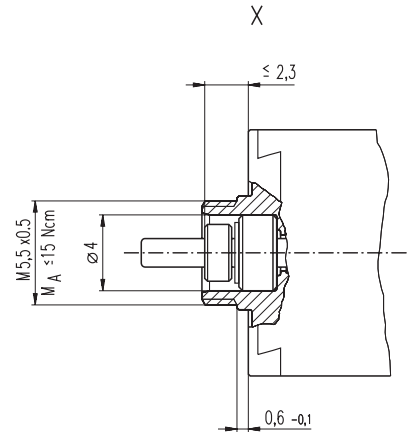
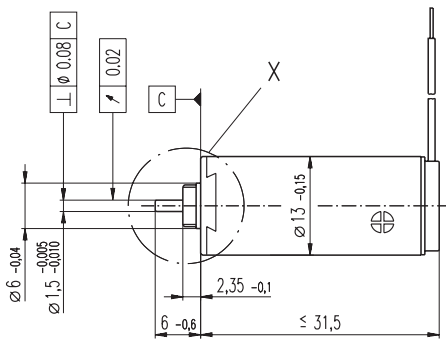
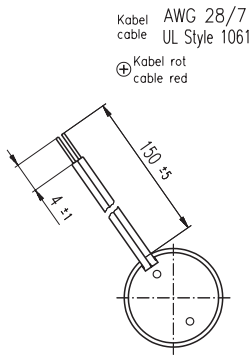

## M 1:1

- Stock program
- Standard program
- Special program (on request)

### Order Number

201353	203937	203938	203939	203940	203941	203942	203943	203944	203945	203946	203947	203948	203949	203950
--------	--------	--------	--------	--------	--------	--------	--------	--------	--------	--------	--------	--------	--------	--------

Motor Data		201353	203937	203938	203939	203940	203941	203942	203943	203944	203945	203946	203947	203948	203949	203950	
<b>Values at nominal voltage</b>																	
1	Nominal voltage	V	2.4	3.0	3.0	3.6	4.8	4.8	6.0	7.2	8.0	10.0	12.0	15.0	15.0	18.0	24.0
2	No load speed	rpm	10600	12300	10800	10900	11500	10200	11500	11500	10900	11500	11100	11200	10400	10600	11600
3	No load current	mA	30.6	31.5	25.1	21.3	17.5	14.3	14.0	11.7	9.66	8.39	6.62	5.35	4.72	4.11	3.55
4	Nominal speed	rpm	9440	10900	9090	8870	9000	7390	8270	7970	7560	8050	7660	7750	6900	7210	8080
5	Nominal torque (max. continuous torque)	mNm	0.97	1.04	1.21	1.45	1.84	2.09	2.32	2.65	2.77	2.71	2.7	2.71	2.7	2.71	2.66
6	Nominal current (max. continuous current)	A	0.480	0.480	0.480	0.480	0.480	0.480	0.480	0.456	0.407	0.335	0.269	0.218	0.201	0.173	0.138
7	Stall torque	mNm	8.91	9.40	7.84	7.90	8.56	7.61	8.35	8.72	9.00	9.08	8.73	8.86	8.10	8.42	8.85
8	Starting current	A	4.15	4.06	2.97	2.52	2.16	1.71	1.69	1.47	1.30	1.10	0.852	0.697	0.591	0.526	0.450
9	Max. efficiency	%	84	84	83	83	83	83	83	83	84	84	84	84	83	84	83
<b>Characteristics</b>																	
10	Terminal resistance	Ω	0.578	0.738	1.01	1.43	2.22	2.81	3.56	4.91	6.16	9.09	14.1	21.5	25.4	34.3	53.3
11	Terminal inductance	mH	0.0157	0.0182	0.0237	0.0334	0.0534	0.0675	0.0834	0.120	0.163	0.232	0.356	0.549	0.638	0.872	1.31
12	Torque constant	mNm / A	2.15	2.31	2.64	3.14	3.96	4.46	4.95	5.94	6.94	8.26	10.2	12.7	13.7	16.0	19.6
13	Speed constant	rpm / V	4450	4130	3610	3040	2410	2140	1930	1610	1380	1160	933	751	697	596	486
14	Speed / torque gradient	rpm / mNm	1200	1320	1380	1390	1350	1350	1380	1330	1220	1270	1280	1270	1290	1270	1320
15	Mechanical time constant	ms	8.50	8.18	7.89	7.66	7.46	7.40	7.38	7.29	7.21	7.22	7.22	7.20	7.20	7.21	7.26
16	Rotor inertia	gcm <sup>2</sup>	0.677	0.592	0.545	0.527	0.527	0.523	0.509	0.525	0.562	0.541	0.537	0.541	0.533	0.540	0.526

### Specifications

- Thermal data**
- 17 Thermal resistance housing-ambient 37 K / W
  - 18 Thermal resistance winding-housing 10 K / W
  - 19 Thermal time constant winding 6.93 s
  - 20 Thermal time constant motor 444 s
  - 21 Ambient temperature -20 ... +65°C
  - 22 Max. permissible winding temperature +85°C
- Mechanical data (sleeve bearings)**
- 23 Max. permissible speed 19000 rpm
  - 24 Axial play 0.05 - 0.15 mm
  - 25 Radial play 0.014 mm
  - 26 Max. axial load (dynamic) 0.8 N
  - 27 Max. force for press fits (static) 35 N
  - 28 Max. radial loading, 5 mm from flange 1.4 N

### Operating Range

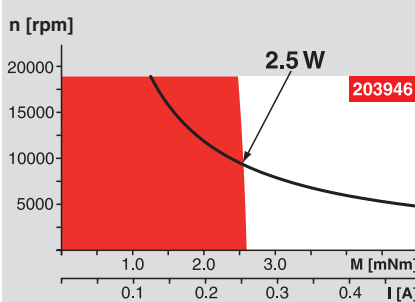

### Comments

- Continuous operation**  
In observation of above listed thermal resistance (lines 17 and 18) the maximum permissible winding temperature will be reached during continuous operation at 25°C ambient.  
= Thermal limit.
- Short term operation**  
The motor may be briefly overloaded (recurring).
- **Assigned power rating**

### Other specifications

- 29 Number of pole pairs 1
  - 30 Number of commutator segments 7
  - 31 Weight of motor 24 g
  - CLL = Capacitor Long Life
  - Alignment of the electronic connections not specified.
- Values listed in the table are nominal.  
Explanation of the figures on page 49.

### maxon Modular System

Overview on page 16 - 21

- Planetary Gearhead**  
Ø13 mm  
0.05 - 0.15 Nm  
Page 217
- Planetary Gearhead**  
Ø13 mm  
0.2 - 0.35 Nm  
Page 218

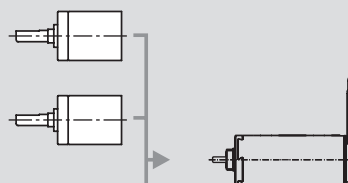

**Recommended Electronics:**  
LSC 30/2 Page 276  
Notes 18