

A-max 26 Ø26 mm, Graphite Brushes, 6 Watt

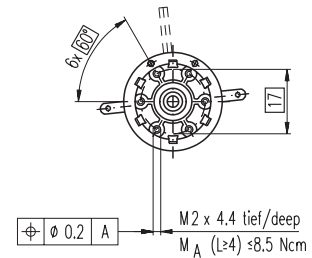
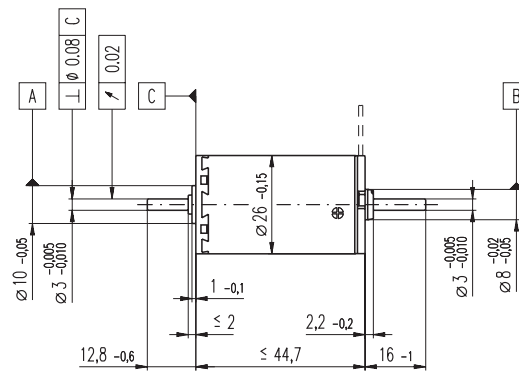
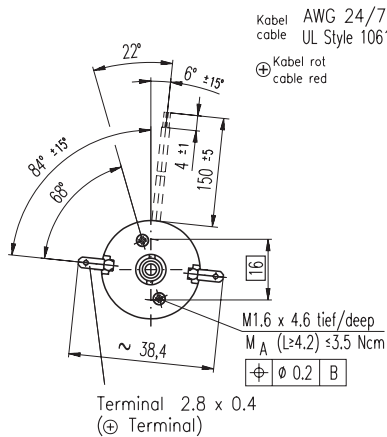

M 1:2

- Stock program
- Standard program
- Special program (on request)

Order Number

with terminals	110946	110947	110948	110949	110950	110951	110952	110953	110954	110955	110956	110957
with cables	353143	353144	353145	353146	353147	353148	353149	353150	353151	353152	353153	353154

Motor Data

Values at nominal voltage														
1	Nominal voltage	V	7.2	9.0	12.0	12.0	18.0	18.0	24.0	24.0	30.0	36.0	42.0	48.0
2	No load speed	rpm	9270	10000	10000	8300	8260	7410	8590	7870	8810	8440	8170	6240
3	No load current	mA	118	104	76.8	59.7	39.2	34.0	30.8	27.6	25.4	20.0	16.4	10.3
4	Nominal speed	rpm	7160	7620	7600	5590	5640	4790	5880	5100	6210	5850	5550	3550
5	Nominal torque (max. continuous torque)	mNm	6.73	7.97	11.1	13.0	13.6	13.8	13.1	12.9	13.7	13.8	13.7	13.7
6	Nominal current (max. continuous current)	A	1.08	1.08	1.08	1.03	0.708	0.642	0.532	0.481	0.452	0.365	0.300	0.201
7	Stall torque	mNm	38.2	39.7	52.7	43.8	45.6	41.0	43.5	38.1	47.9	46.4	43.7	32.6
8	Starting current	A	5.50	4.90	4.80	3.29	2.25	1.82	1.67	1.34	1.51	1.16	0.911	0.455
9	Max. efficiency	%	67	69	73	72	74	73	74	73	75	75	75	72
Characteristics														
10	Terminal resistance	Ω	1.31	1.84	2.50	3.65	8.00	9.91	14.4	17.9	19.9	31.0	46.1	106
11	Terminal inductance	mH	0.101	0.138	0.254	0.372	0.862	1.07	1.42	1.69	2.13	3.35	4.85	10.8
12	Torque constant	mNm / A	6.94	8.09	11.0	13.3	20.2	22.5	26.0	28.3	31.8	39.9	48.0	71.6
13	Speed constant	rpm / mNm	1380	1180	869	718	472	423	367	337	300	239	199	133
14	Speed / torque gradient	rpm / mNm	260	268	198	197	186	186	203	213	188	186	191	197
15	Mechanical time constant	ms	33.4	30.5	27.9	27.1	25.4	25.2	24.9	24.9	24.5	24.3	24.2	24.2
16	Rotor inertia	gcm ²	12.3	10.9	13.5	13.2	13.0	12.9	11.7	11.2	12.5	12.5	12.1	11.7

Specifications

- Thermal data**
- 17 Thermal resistance housing-ambient 13.2 K / W
 - 18 Thermal resistance winding-housing 3.2 K / W
 - 19 Thermal time constant winding 12.4 s
 - 20 Thermal time constant motor 660 s
 - 21 Ambient temperature -30 ... +85°C
 - 22 Max. permissible winding temperature +125°C
- Mechanical data (ball bearings)**
- 23 Max. permissible speed 10400 rpm
 - 24 Axial play 0.1 - 0.2 mm
 - 25 Radial play 0.025 mm
 - 26 Max. axial load (dynamic) 5 N
 - 27 Max. force for press fits (static) 75 N (static, shaft supported) 1200 N
 - 28 Max. radial loading, 5 mm from flange 20.5 N
- Mechanical data (sleeve bearings)**
- 23 Max. permissible speed 10400 rpm
 - 24 Axial play 0.1 - 0.2 mm
 - 25 Radial play 0.012 mm
 - 26 Max. axial load (dynamic) 1.7 N
 - 27 Max. force for press fits (static) 80 N (static, shaft supported) 1200 N
 - 28 Max. radial loading, 5 mm from flange 5.5 N
- Other specifications**
- 29 Number of pole pairs 1
 - 30 Number of commutator segments 13
 - 31 Weight of motor 100 g

Values listed in the table are nominal.
Explanation of the figures on page 49.

Option

Sleeve bearings in place of ball bearings

Operating Range

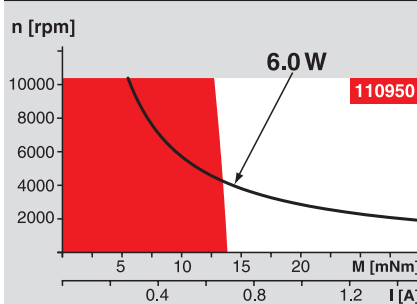

Comments

Continuous operation
In observation of above listed thermal resistance (lines 17 and 18) the maximum permissible winding temperature will be reached during continuous operation at 25°C ambient.
= Thermal limit.

Short term operation
The motor may be briefly overloaded (recurring).

— Assigned power rating

maxon Modular System

- Planetary Gearhead**
Ø26 mm
0.5 - 2.0 Nm
Page 235
- Spur Gearhead**
Ø30 mm
0.07 - 0.2 Nm
Page 236
- Planetary Gearhead**
Ø32 mm
0.4 - 6.0 Nm
Page 237 / 238 / 241
- Spur Gearhead**
Ø38 mm
0.1 - 0.6 Nm
Page 243

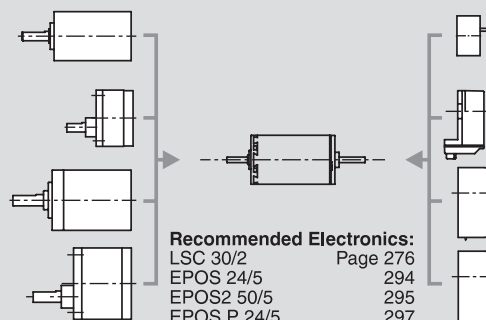

Recommended Electronics:
LSC 30/2 Page 276
EPOS 24/5 294
EPOS2 50/5 295
EPOS P 24/5 297
Notes 18

Overview on page 16 - 21

- Encoder MR**
128 - 1000 CPT,
3 channels
Page 258
- Encoder Enc**
22 mm
100 CPT, 2 channels
Page 261
- Encoder HEDS 5540**
500 CPT,
3 channels
Page 263
- Encoder HDL 5540**
500 CPT,
3 channels
Page 265