

# A-max 22 Ø22 mm, Precious Metal Brushes CLL, 5 Watt, CE approved

Kabel AWG 24/7  
cable UL Style 1061  
⊕ Kabel rot  
cable red

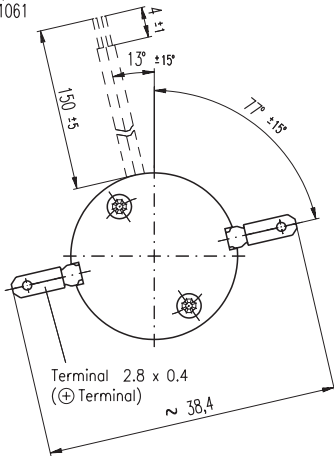

M 1:1

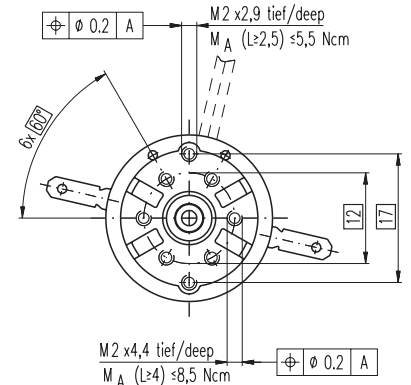
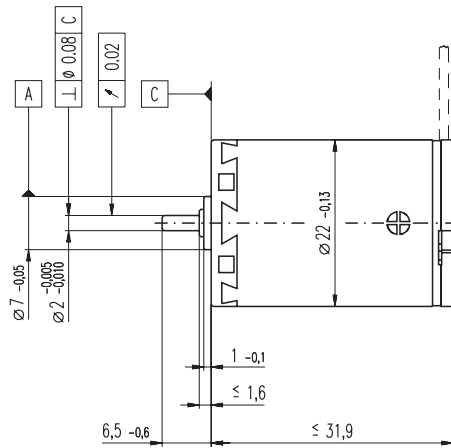

- █ Stock program
- Standard program
- Special program (on request)

## Order Number

with terminals  
with cables

110117	110119	110120	110121	110122	110123	110124	110125	110126	110127	110128	110129
139838	218799	238798	202413	258367	137255	134267	134666	267423	137476	310003	342390

## Motor Data

Values at nominal voltage		110117	110119	110120	110121	110122	110123	110124	110125	110126	110127	110128	110129	
1	Nominal voltage	V	6.0	9.0	9.0	12.0	12.0	15.0	18.0	24.0	30.0	36.0	48.0	48.0
2	No load speed	rpm	9640	9980	8770	10400	9410	10300	9970	10700	10800	9800	9290	8380
3	No load current	mA	29.6	20.9	16.9	16.9	14.2	13.1	10.4	8.83	7.20	5.07	3.48	2.94
4	Nominal speed	rpm	7480	7350	6150	7820	6760	7620	7310	8060	8160	7090	6520	5620
5	Nominal torque (max. continuous torque)	mNm	4.81	6.33	6.42	6.36	6.31	6.29	6.25	6.23	6.18	6.15	6.03	6.10
6	Nominal current (max. continuous current)	A	0.840	0.757	0.673	0.597	0.533	0.465	0.374	0.301	0.241	0.181	0.126	0.115
7	Stall torque	mNm	21.5	24.1	21.5	25.5	22.5	24.5	23.5	25.2	25.1	22.3	20.3	18.6
8	Starting current	A	3.65	2.81	2.21	2.34	1.86	1.77	1.37	1.19	0.957	0.641	0.414	0.343
9	Max. efficiency	%	83	84	84	84	84	84	84	84	84	83	83	83
Characteristics														
10	Terminal resistance	Ω	1.64	3.20	4.07	5.13	6.46	8.48	13.1	20.2	31.3	56.2	116	140
11	Terminal inductance	mH	0.106	0.222	0.288	0.362	0.445	0.584	0.890	1.37	2.10	3.68	7.29	8.95
12	Torque constant	mNm / A	5.90	8.55	9.73	10.9	12.1	13.9	17.1	21.2	26.2	34.8	48.9	54.3
13	Speed constant	rpm / V	1620	1120	981	875	790	689	558	450	364	274	195	176
14	Speed / torque gradient	rpm / mNm	452	418	410	412	422	422	428	429	435	443	462	454
15	Mechanical time constant	ms	19.1	18.8	18.7	18.7	18.7	18.7	18.7	18.8	18.8	18.9	19.1	19.0
16	Rotor inertia	gcm <sup>2</sup>	4.04	4.29	4.35	4.33	4.24	4.24	4.18	4.18	4.14	4.07	3.95	3.99

## Specifications

- Thermal data**
- 17 Thermal resistance housing-ambient 20 K / W
  - 18 Thermal resistance winding-housing 6.0 K / W
  - 19 Thermal time constant winding 10.1 s
  - 20 Thermal time constant motor 540 s
  - 21 Ambient temperature -30 ... +65°C
  - 22 Max. permissible winding temperature +85°C
- Mechanical data (sleeve bearings)**
- 23 Max. permissible speed 16000 rpm
  - 24 Axial play 0.05 - 0.15 mm
  - 25 Radial play 0.012 mm
  - 26 Max. axial load (dynamic) 1 N
  - 27 Max. force for press fits (static) 80 N
  - 28 Max. radial loading, 5 mm from flange 2.8 N
- Mechanical data (ball bearings)**
- 23 Max. permissible speed 16000 rpm
  - 24 Axial play 0.05 - 0.15 mm
  - 25 Radial play 0.025 mm
  - 26 Max. axial load (dynamic) 3.3 N
  - 27 Max. force for press fits (static) 45 N
  - 28 Max. radial loading, 5 mm from flange 12.3 N
- Other specifications**
- 29 Number of pole pairs 1
  - 30 Number of commutator segments 9
  - 31 Weight of motor 54 g
- CLL = Capacitor Long Life

Values listed in the table are nominal.  
Explanation of the figures on page 49.

### Option

Ball bearings in place of sleeve bearings  
Without CLL

## Operating Range

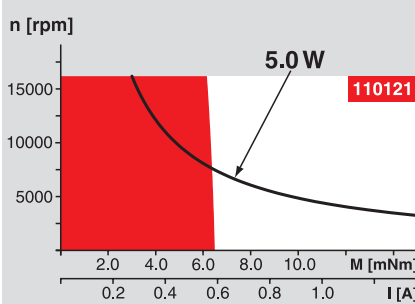

## Comments

█ **Continuous operation**  
In observation of above listed thermal resistance (lines 17 and 18) the maximum permissible winding temperature will be reached during continuous operation at 25°C ambient.  
= Thermal limit.

**Short term operation**  
The motor may be briefly overloaded (recurring).

— Assigned power rating

## maxon Modular System

Overview on page 16 - 21

### Planetary Gearhead

Ø22 mm  
0.1 - 0.6 Nm  
Page 228 / 229

### Planetary Gearhead

Ø22 mm  
0.5 - 1.0 Nm  
Page 230

### Planetary Gearhead

Ø22 mm  
0.5 - 2.0 Nm  
Page 231

### Spur Gearhead

Ø24 mm  
0.1 Nm  
Page 234

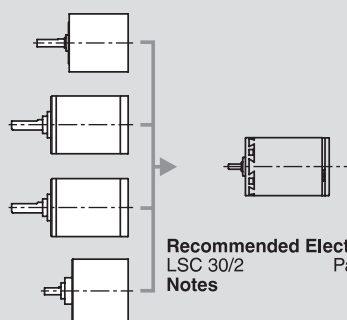

**Recommended Electronics:**  
LSC 30/2 Page 276  
Notes 18