

# EC 9.2 flat $\varnothing 10$ mm, brushless, 0.5 Watt

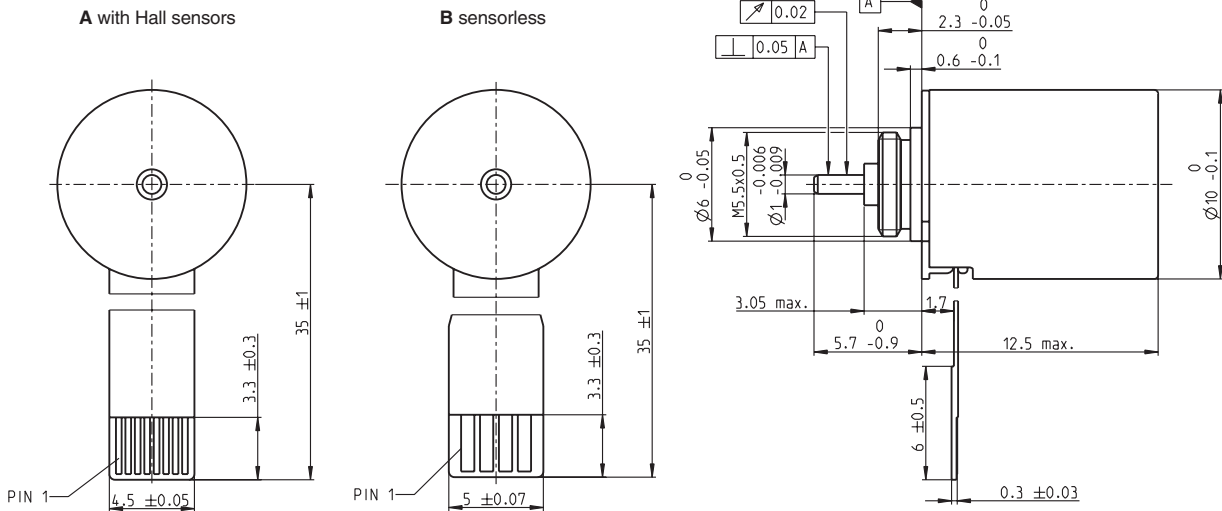

**M 2.5:1**

- Stock program
- Standard program
- Special program (on request)

Order Number			
A with Hall sensors	362790	370444	370445
B sensorless	371119	371120	371122

Motor Data (provisional)				
Values at nominal voltage				
	V	3.0	4.5	6.0
1 Nominal voltage	V	3.0	4.5	6.0
2 No load speed	rpm	14700	15400	15900
3 No load current	mA	58.8	41.6	33.3
4 Nominal speed	rpm	3720	4130	4010
5 Nennmoment	mNm	0.829	0.879	0.742
6 Nennstrom	A	0.5	0.366	0.248
7 Stall torque	mNm	1.19	1.29	1.07
8 Starting current	A	0.675	0.507	0.332
9 Max. efficiency	%	51	52	48
Characteristics				
10 Terminal resistance phase to phase	$\Omega$	4.44	8.88	18.1
11 Terminal inductance phase to phase	mH	0.12	0.25	0.4
12 Torque constant	mNm / A	1.77	2.55	3.23
13 Speed constant	rpm / V	5400	3740	2960
14 Speed / torque gradient	rpm / mNm	13600	13000	16600
15 Mechanical time constant	ms	20.3	28.3	24.8
16 Rotor inertia	gcm <sup>2</sup>	0.143	0.143	0.143

Specifications	
<b>Thermal data</b>	
17 Thermal resistance housing-ambient	49.2 K / W
18 Thermal resistance winding-housing	13.2 K / W
19 Thermal time constant winding	1.47 s
20 Thermal time constant motor	38.1 s
21 Ambient temperature	-20 ... +85°C
22 Max. permissible winding temperature	+100°C
<b>Mechanical data (preloaded ball bearings)</b>	
23 Max. permissible speed	25000 rpm
24 Axial play at axial load < 5.0 N	0 mm
> 5.0 N	0.1 mm
25 Radial play	preloaded
26 Max. axial load (dynamic)	0.15 N
27 Max. force for press fits (static)	15 N
(static, shaft supported)	70 N
28 Max. radial loading, 4 mm from flange	0.4 N

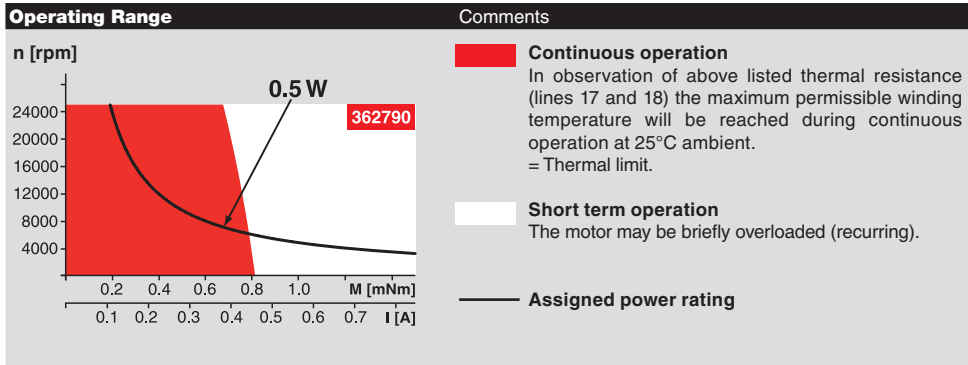

Other specifications		
29 Number of pole pairs		4
30 Number of phases		3
31 Weight of motor		3 g

Values listed in the table are nominal.

Connection	with Hall sensors	sensorless
Pin 1	Motor winding 1	Motor winding 1
Pin 2	Motor winding 2	Motor winding 2
Pin 3	Motor winding 3	Motor winding 3
Pin 4	V <sub>Hall</sub> 4.5...18 VDC	Y
Pin 5	GND	
Pin 6	Hall sensor 1	
Pin 7	Hall sensor 2	
Pin 8	Hall sensor 3	

Connector	Article number	Article number
FCI	SFV8R-2STE1LF	
Global Shine	GS200-08 1 1 1-2	
MOLEX	52745-0896	52207-0485
MOLEX		52089-0419
TYCO		84953-4

Pin for design with Hall sensors:  
FPC, 8-pol, Pitch 0.5 mm, top contact style  
Wiring diagram for Hall sensors see p. 29

maxon Modular System		Overview on page 16 - 21
<p><b>Planetary Gearhead</b> <math>\varnothing 10</math> mm 0.005 - 0.1 Nm Page 205</p> <p><b>Planetary Gearhead</b> <math>\varnothing 10</math> mm 0.01 - 0.15 Nm Page 206</p>		<p><b>Recommended Electronics:</b> DECS 50/5 Page 289 DEC 24/1 <b>381510</b> 289 DEC Module 24/2 290 <b>Notes</b> 20</p>
<p><b>Option</b> Sleeve bearings in place of ball bearings</p>		