

EC 25 Ø25 mm, brushless, 250 Watt

High Speed

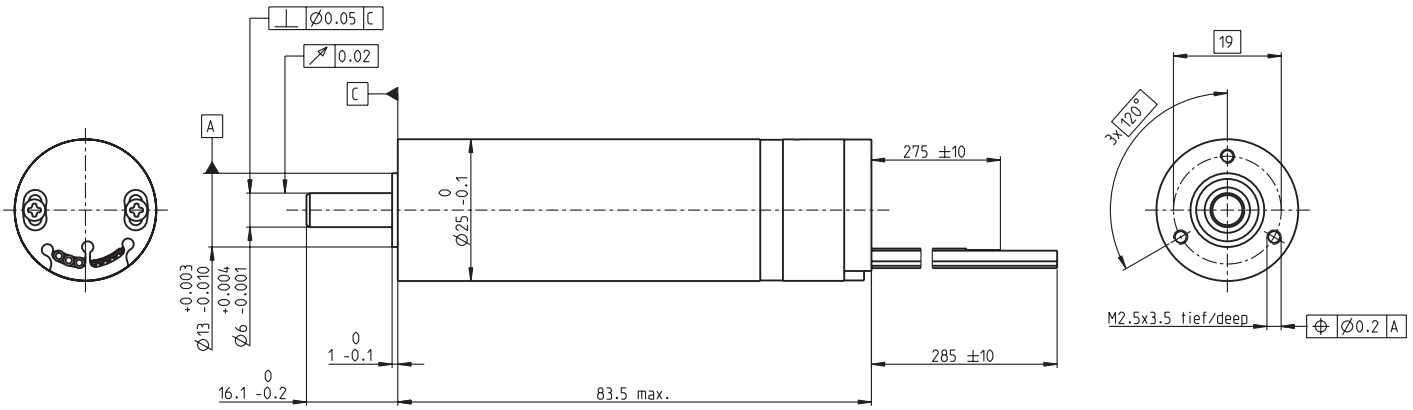

M 3:2

- Stock program
- Standard program
- Special program (on request)

Order Number

351144

Motor Data (provisional)			
Values at nominal voltage			
1 Nominal voltage	V	36.0	
2 No load speed	rpm	64100	
3 No load current	mA	279	
4 Nominal speed	rpm	62000	
5 Nominal torque (max. continuous torque)	mNm	38.1	
6 Nominal current (max. continuous current)	A	7.32	
7 Stall torque	mNm	1580	
8 Starting current	A	294	
9 Max. efficiency	%	94	
Characteristics			
10 Terminal resistance phase to phase	Ω	0.122	
11 Terminal inductance phase to phase	mH	0.0137	
12 Torque constant	mNm / A	5.36	
13 Speed constant	rpm / V	1780	
14 Speed / torque gradient	rpm / mNm	40.6	
15 Mechanical time constant	ms	2.32	
16 Rotor inertia	gcm ²	5.45	

Specifications	Operating Range	Comments
<p>Thermal data</p> <p>17 Thermal resistance housing-ambient 6.52 K / W</p> <p>18 Thermal resistance winding-housing 0.331 K / W</p> <p>19 Thermal time constant winding 1.61 s</p> <p>20 Thermal time constant motor 331 s</p> <p>21 Ambient temperature -20 ... +100°C</p> <p>22 Max. permissible winding temperature +125°C</p> <p>Mechanical data (preloaded ball bearings)</p> <p>23 Max. permissible speed 70000 rpm</p> <p>24 Axial play at axial load < 9 N 0 mm</p> <p style="padding-left: 20px;">> 9 N max. 0.14 mm</p> <p>25 Radial play 0.025 mm</p> <p>26 Max. axial load (dynamic) 7 N</p> <p>27 Max. force for press fits (static) 87 N</p> <p style="padding-left: 20px;">(static, shaft supported) 5080 N</p> <p>28 Max. radial loading, 5 mm from flange 20 N</p> <p>Other specifications</p> <p>29 Number of pole pairs 1</p> <p>30 Number of phases 3</p> <p>31 Weight of motor 240 g</p>		<p>Continuous operation</p> <p>In observation of above listed thermal resistance (lines 17 and 18) the maximum permissible winding temperature will be reached during continuous operation at 25°C ambient. = Thermal limit.</p> <p>Short term operation</p> <p>The motor may be briefly overloaded (recurring).</p> <p>Assigned power rating</p>

maxon Modular System Overview on page 16 - 21

Values listed in the table are nominal.

Connection, Motor (Cable AWG 18)

red Motor winding 1

black Motor winding 2

white Motor winding 3

Connection, sensors (Cable AWG 26)

green V_{Hall} 4.5 ... 24 VDC

blue GND

red / grey Hall sensor 1

black / grey Hall sensor 2

white / grey Hall sensor 3

Recommended Electronics:
 DEC 70/10 Page 297
 Notes 20