

# A-max 19 Ø19 mm, Precious Metal Brushes CLL, 1.5 Watt, CE approved

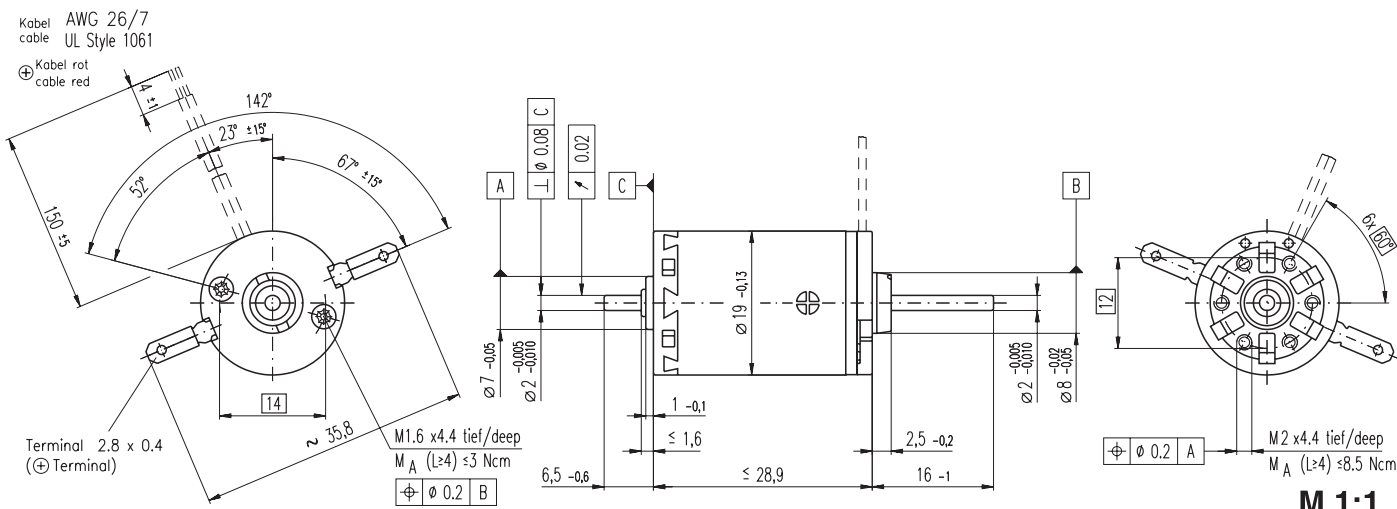

- Stock program
- Standard program
- Special program (on request)

		Order Number								
with terminals		110090	110091	110092	110093	110094	110095	110096	110097	110098
with cables		139832	352925	352926	352927	352928	352929	352930	315468	352931

Motor Data																				
Values at nominal voltage																				
1	Nominal voltage	V	1.2	2.4	3.0	4.8	6.0	7.2	9.0	12.0	18.0									
2	No load speed	rpm	6360	7150	6210	6180	6080	6120	6120	6140	6580									
3	No load current	mA	88.0	51.9	34.1	21.2	16.6	13.9	11.1	8.39	6.17									
4	Nominal speed	rpm	5030	4380	2490	2430	2360	2320	2310	2300	2670									
5	Nominal torque (max. continuous torque)	mNm	1.34	2.49	3.62	3.59	3.63	3.55	3.54	3.51	3.42									
6	Nominal current (max. continuous current)	A	0.840	0.840	0.831	0.513	0.407	0.335	0.267	0.200	0.139									
7	Stall torque	mNm	6.50	6.53	6.13	6.01	6.01	5.80	5.79	5.72	5.85									
8	Starting current	A	3.69	2.09	1.36	0.832	0.655	0.53	0.423	0.314	0.23									
9	Max. efficiency	%	72	72	71	71	71	71	71	71	71									
Characteristics																				
10	Terminal resistance	Ω	0.325	1.15	2.20	5.77	9.17	13.6	21.3	38.2	78.2									
11	Terminal inductance	mH	0.0186	0.0587	0.121	0.314	0.506	0.719	1.12	1.98	3.87									
12	Torque constant	mNm / A	1.76	3.13	4.50	7.23	9.19	10.9	13.7	18.2	25.4									
13	Speed constant	rpm / V	5430	3050	2120	1320	1040	873	698	525	376									
14	Speed / torque gradient	rpm / mNm	1000	1120	1040	1050	1040	1080	1090	1100	1160									
15	Mechanical time constant	ms	26.7	24.4	23.7	23.6	23.5	23.7	23.7	23.8	24.1									
16	Rotor inertia	gcm <sup>2</sup>	2.54	2.07	2.18	2.14	2.16	2.09	2.09	2.06	1.99									

Specifications		
Thermal data		
17	Thermal resistance housing-ambient	21.3 K / W
18	Thermal resistance winding-housing	10.5 K / W
19	Thermal time constant winding	11 s
20	Thermal time constant motor	362 s
21	Ambient temperature	-30 ... +65°C
22	Max. permissible winding temperature	+85°C
Mechanical data (sleeve bearings)		
23	Max. permissible speed	10000 rpm
24	Axial play	0.05 - 0.15 mm
25	Radial play	0.012 mm
26	Max. axial load (dynamic)	1 N
27	Max. force for press fits (static) (static, shaft supported)	80 N / 480 N
28	Max. radial loading, 5 mm from flange	2.7 N
Mechanical data (ball bearings)		
23	Max. permissible speed	10000 rpm
24	Axial play	0.05 - 0.15 mm
25	Radial play	0.025 mm
26	Max. axial load (dynamic)	3.3 N
27	Max. force for press fits (static) (static, shaft supported)	45 N / 480 N
28	Max. radial loading, 5 mm from flange	11.9 N
Other specifications		
29	Number of pole pairs	1
30	Number of commutator segments	9
31	Weight of motor	34 g
		CLL = Capacitor Long Life
		Values listed in the table are nominal. Explanation of the figures on page 49.

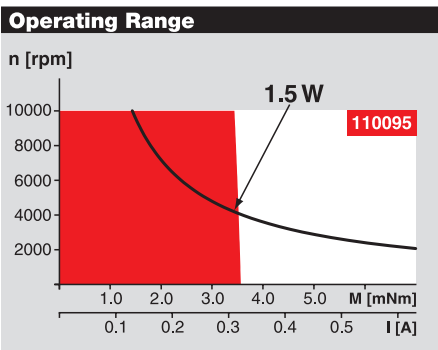

**Comments**

**Continuous operation**  
In observation of above listed thermal resistance (lines 17 and 18) the maximum permissible winding temperature will be reached during continuous operation at 25°C ambient.  
= Thermal limit.

**Short term operation**  
The motor may be briefly overloaded (recurring).

— **Assigned power rating**

Option	
Ball bearings in place of sleeve bearings Without CLL	

maxon Modular System		Overview on page 16 - 21
<p><b>Planetary Gearhead</b> Ø19 mm 0.1 - 0.3 Nm Page 226</p> <p><b>Spur Gearhead</b> Ø20.3 mm 0.06 - 0.25 Nm Page 227</p> <p><b>Planetary Gearhead</b> Ø22 mm 0.1 - 2.0 Nm Page 228 / 230 / 231</p> <p><b>Spur Gearhead</b> Ø24 mm 0.1 Nm Page 234</p>		<p><b>Encoder MR</b> 32 CPT, 2 / 3 channels Page 255</p> <p><b>Encoder MR</b> 128 / 256 / 512 CPT, 2 / 3 channels Page 256</p> <p><b>Encoder Enc</b> 22 mm 100 CPT, 2 channels Page 261</p> <p><b>Encoder MEnc</b> Ø13 mm 16 CPT, 2 channels Page 270</p>
<p><b>Recommended Electronics:</b> LSC 30/2 Notes Page 276 18</p>		