

IG-500N

Redefine motion limits...

GPS aided Orientation Sensor



The IG-500N is the world smallest GPS enhanced Attitude and Heading Reference System (AHRS). With its embedded Extended Kalman Filter, the IG-500N delivers unmatched precision for attitude and position measurements in very high dynamic conditions.

All in one: the IG-500N

The IG-500N includes a MEMS based Inertial Measurement Unit (IMU), a GPS receiver and a pressure sensor. It provides precise drift-free attitude and position, even in long time turns.

This miniature Inertial Navigation System (INS) runs a real time, on board, Extended Kalman Filter that computes orientation, position and velocity data at high update rates, up to 100 Hz.

The attitude accuracy is also improved, compared to traditional AHRS, by removing transient accelerations measured by the GPS receiver.

Easy and fast integration

SBG Systems has designed a powerful and easy to use Development Kit for this product. In just a few seconds, you can start evaluating and configuring your new device. Integrating the IG-500N in your application is even easier.

Simplified Block Diagram

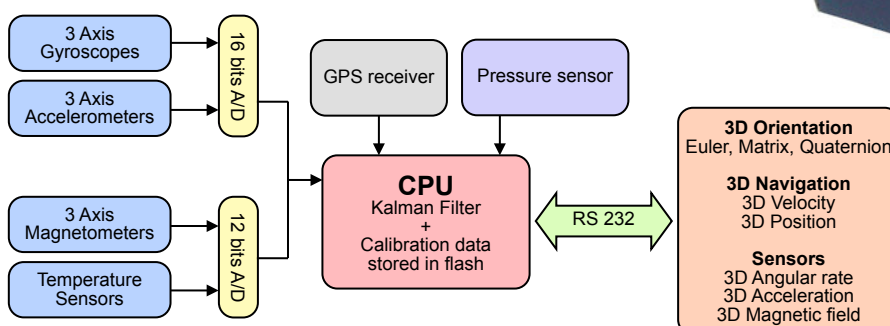

Key Features

- GPS enhanced 3d velocity, position and orientation at high update rate (100 Hz)
- Accurate attitude even in high G maneuvers
- Precise UTC referenced output
- Embedded 4Hz GPS receiver & barometric sensor
- Wide inertial sensors range options
- Calibrated over full temperature range -40 to 85°C for bias, gain, misalignments, cross-axis and gyro-g
- Advanced and easy to use magnetometers compensation procedure for soft and hard iron
- Communication protocols : RS-232, CAN and USB
- Very compact and lightweight design (44 grams)
- Very low power design down to 550 mW
- Robust and high precision aluminum enclosure

Fields of use

- Unmanned vehicles
- Vehicle motion analysis
- Aerospace
- Robotics
- Marine industry



Technical Specifications

Parameter	Specification	Remarks		
Attitude				
Sensing range	360° in all axes			
Static accuracy	± 0.5° (Pitch, Roll) ± 1° (Heading)	Stabilized Kalman Filter Homogenous magnetic field		
Dynamic accuracy	± 1.0° RMS	Under good GPS availability		
Repeatability	< 0.2°			
Resolution	< 0.05°			
Output frequency	0 to 500 Hz 0 to 100 Hz	Calibrated sensors only Sensors, attitude, velocity, position		
Standard Sensors				
	Accelerometers	Gyroscopes	Magnetometers	
Measurement range	± 5 g	± 300 °/s	± 1.2 Gauss	Refer to sensors options table
Non-linearity	< 0.2% of FS	< 0.1% of FS	< 0.2% of FS	
Bias stability	± 5 mg	± 0.5 °/s	± 0.5 mGauss	Over temperature range Kalman filter stabilized
	-	< 0.1 °/s	-	
Scale factor stability	< 0.1%	< 0.05%	< 0.5%	Over temperature range
Noise density	0.25 mg/√Hz	0.05 °/s/√Hz	0.01 mG/√Hz	
Alignment error	< 0.1°	< 0.1°	< 0.1°	
Bandwidth	50 Hz	40 Hz	500 Hz	Additional software filter available
Sampling rate	10 000 Hz	10 000 Hz	1 000 Hz	
GPS Receiver				
Receiver type	L1 frequency, C/A Code, 16-Channels, 4 Hz			
Position accuracy	2.0 meters 2.5 meters 5.0 meters	with SBAS support CEP (Horizontal accuracy) SEP (Vertical accuracy)		
Acquisition time	< 3.5 s / 34 s			
Tracking sensitivity	-158 dB			
Pressure Sensor				
Resolution	6 Pa			
Pressure accuracy	± 50 Pa ± 200 Pa	Relative Absolute		
Long term stability	100 Pa			
Update rate	9 Hz			
Communication				
Output modes	Euler angles, Quaternion, Matrix, 3d velocity, 3d position, Calibrated sensor data, Raw sensor data	Each output can be enabled or disabled by the user		
Interface options	Serial (RS-232 or TTL 3.3V) CAN 2.0A/B up to 1 Mbit/s Usb using provided UsbToUart			
Serial data rate	9 600 to 921 600 bps		User selectable	
Physical				
Dimensions OEM	27x30x14 mm			
Dimensions box	36x49x22 mm			
Weight OEM	10 grams			
Weight box	44 grams			
Specified temperature	-40 to 85°C		Non-condensing environment	
Storage temperature	-40 to 85°C			
Shock limit	1 000g (Powered), 2 000g (Unpowered)		Shocks can affect performance	
Electrical				
Operating voltage	3.3 V to 30 V			
Power consumption	550 mW @ 5.0 V		High efficiency DC/DC converter	
Start-up time	< 1 s			

Mechanical drawing

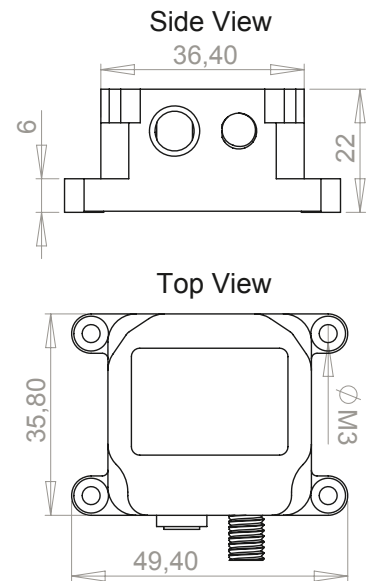

All dimensions are in millimeters

Product code options

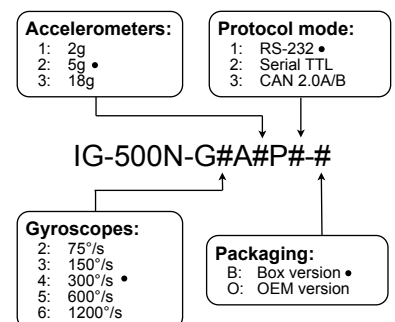

• standard product options